

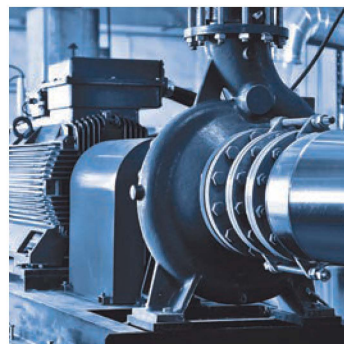

Grupa Powen-Wafapomp SA

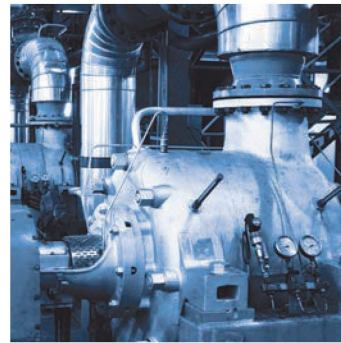
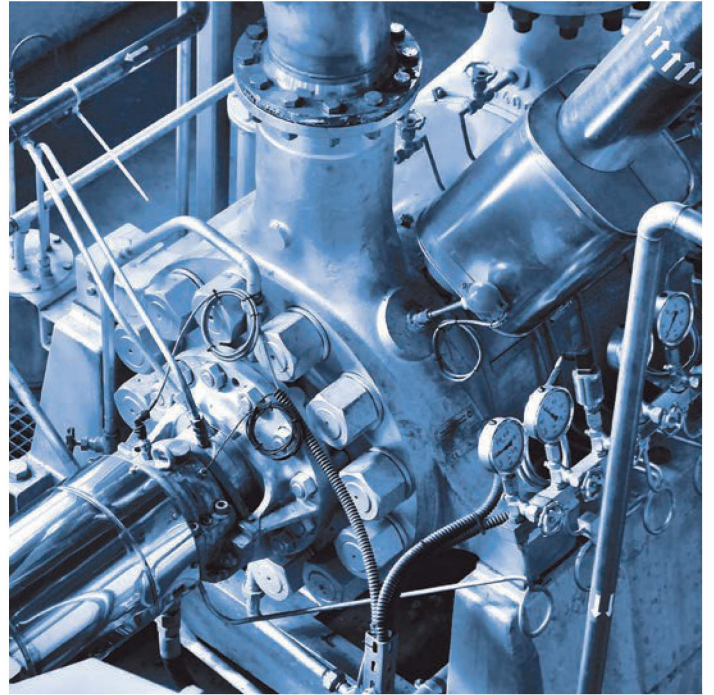

*Pumps for Power and Heat
Supplying Industries*
2017 catalogue

Basic pumps

Supply pumps

Z		4
YS		10

Condensate pumps

K i WK		20
---------------	--	----

Cooling water pumps

D		26
P		32

Hot water pumps

B i BV		36
WN		42
W		48
A-P		54
AP-10		60

Stationary pumps

A		66
FY		72

Stationary slurry pumps

MF		76
PH		80
HC		86

Submersible slurry pumps

HZ		90
-----------	--	----

Submersible pumps

OSZ		94
SP		98
NZ		102
P-BA		106

PUMPS IN A POWER PLANT AND HEAT GENERATING PLANT

examples of application

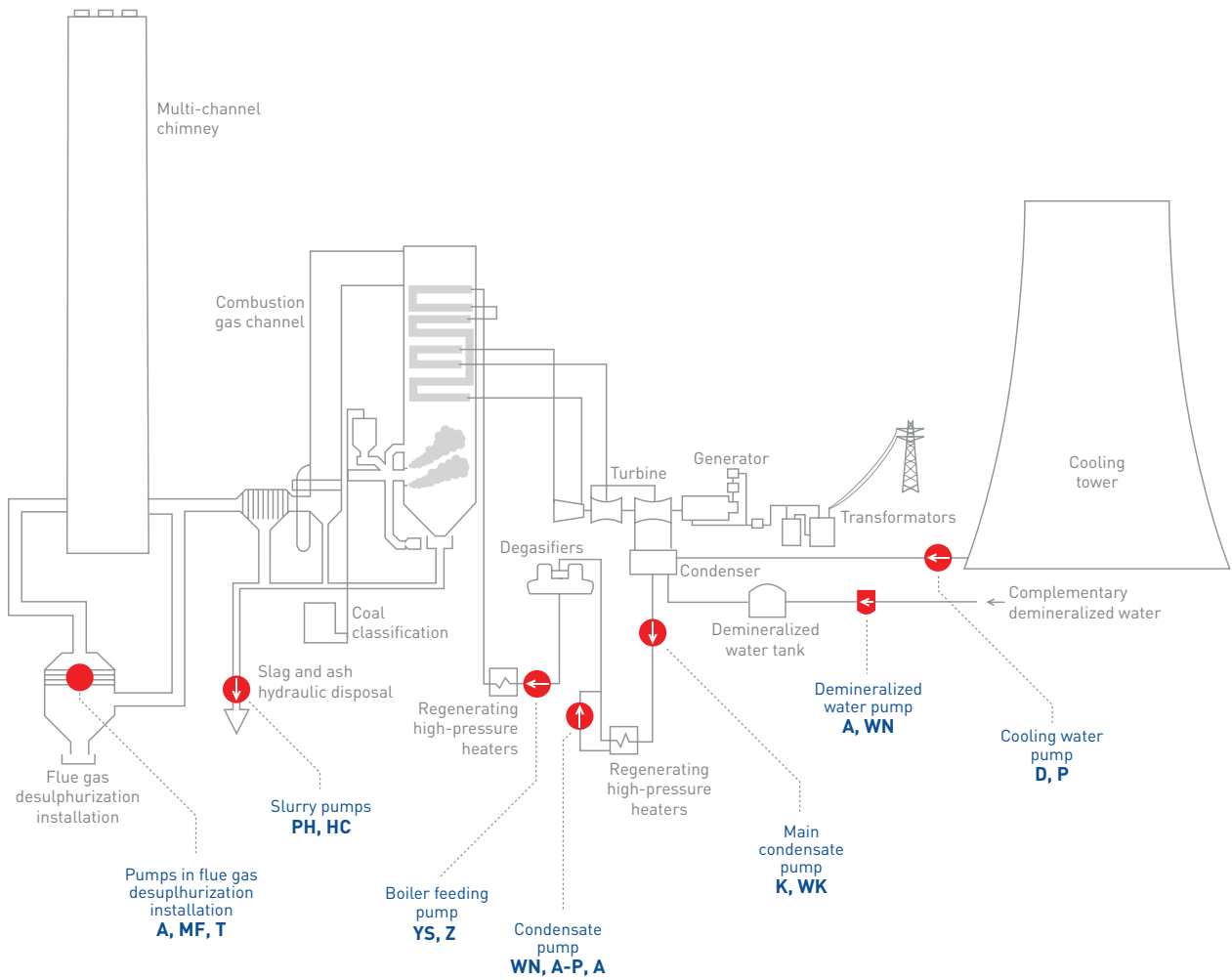

SUPPLY PUMPS

Z

Z pumps are designed to operate as boiler feeding pumps for pumping clean and hot water in power plants

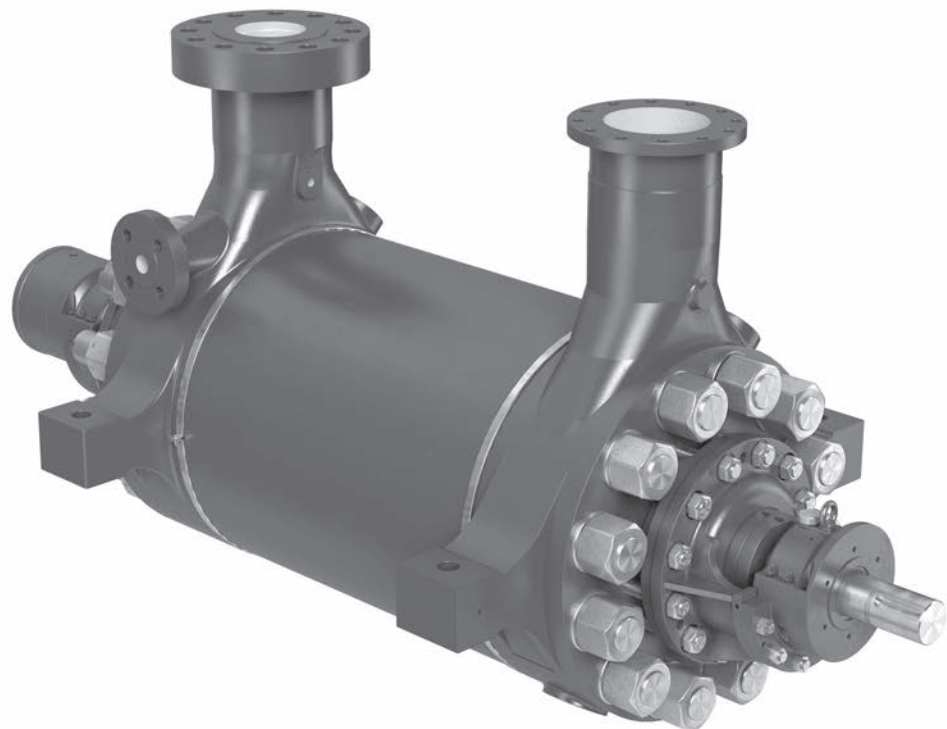

APPLICATION

Z-type pumps are designed to operate as boiler feeding pumps in power plants.

They can also be applied in any other industrial application where clean, hot water of pressure up to 230 bar is required.

DESIGN

Horizontal, multistage, ring-section centrifugal pumps designed to handle hot water. The pumps are supported at the axis. Both suction and delivery flanges are directed vertically upwards. Version with the suction flange directed downwards is also available. The axial thrust is absorbed by a balance disk. In order to protect the balance disk during start-up the pumps are equipped with an additional axial Mitchell type bearing, which supports the balance disk during the transient period before the pump reaches the full operating speed. The slide bearings are oil lubricated with forced lubricating system consisting of auxiliary oil pump, oil filter and cooler. The pumps are equipped with mechanical seals.

Typically, Z type pumps are delivered with auxiliaries such as: suction filter, minimal flow valve, pressure gauges, temperature and vibration sensors.

MATERIALS OF CONSTRUCTION

The materials of construction are selected for hot, demineralized boiler water. Chromium steel and chromium cast steel are applied as standard for main pump elements. Alternative, special materials can be selected if necessary.

CROSS-SECTION / LIST OF PUMP PARTS

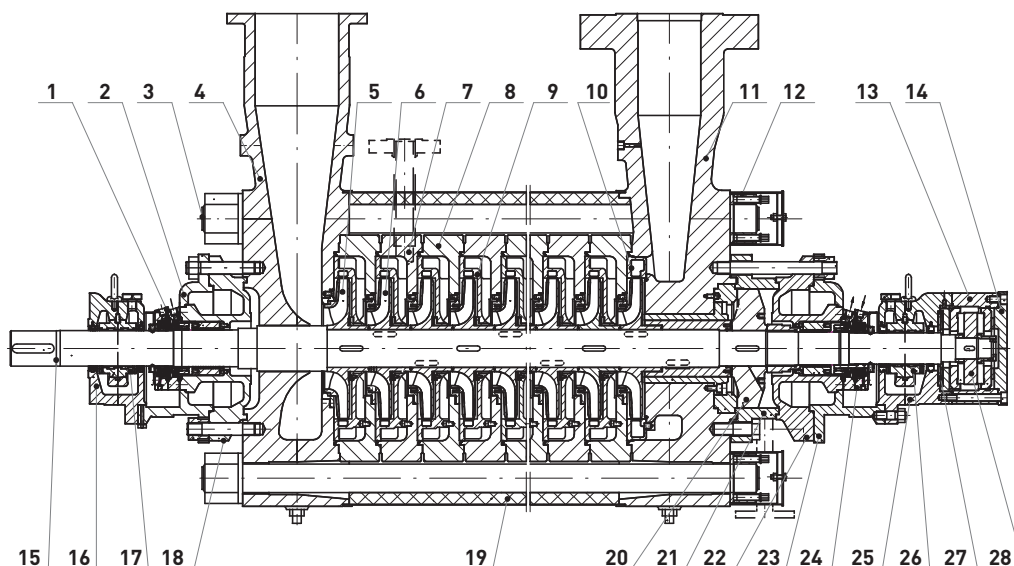

No.	Part name	No.	Part name
1	Mechanical seal	15	Shaft
2	Stuffing box cover	16	Bearing housing
3	Tie bolt	17	Bush
4	Suction casing	18	Stuffing box
5	Impeller 1	19	Shield
6	Impeller	20	Balance disk
7	Stage casing with bleeder	21	Stuffing box spacer
8	Stage casing	22	Stuffing box
9	Stator	23	Stuffing box cover
10	Stator	24	Mechanical seal
11	Discharge casing	25	Bearing housing
12	Superbolt nut	26	Bush
13	Thrust bearing housing	27	Dish spring
14	Thrust bearing cover	28	Counter balance disk

DIMENSIONS

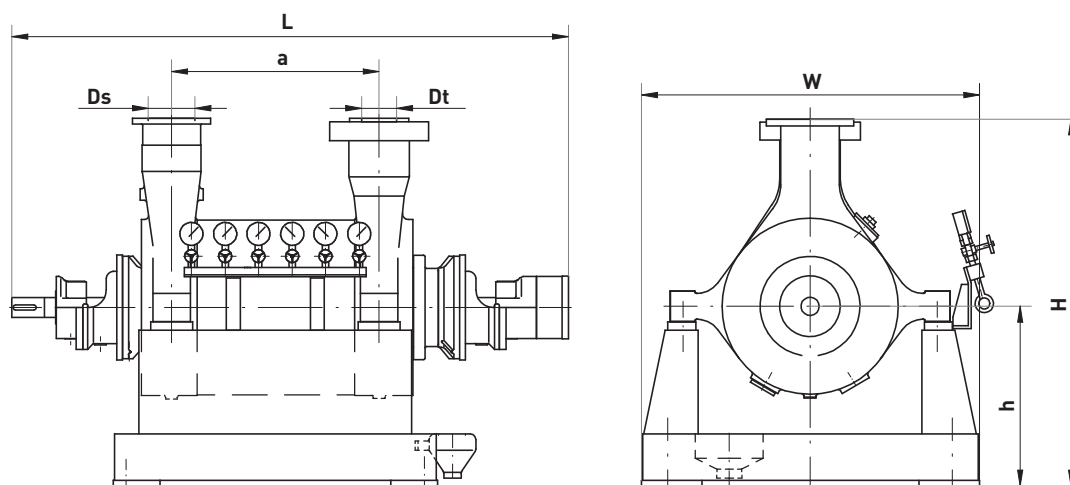

Pump type	Number of stages	Dimensions [mm]							Weight m [kg]						
		L	a	W	H	h	Ds	Dt							
15Z28	3	1782	350	1280	1330	700	200	150	2500						
	4	1872	440						2620						
	5	1962	530						2740						
	6	2032	620						2860						
	7	2122	710						2980						
	8	2212	800						3100						
	9	2302	890						3220						
	10	2392	980						3340						
	11	2482	1070						3460						
	12	2572	1160						3580						
	13	2662	1250						3700						
	15Z33	3	1887						390	1450	1547	747	200	150	2600
		4	1987						490						2760
5		2087	590	2920											
6		2187	690	3080											
7		2287	790	3260											
8		2387	890	3420											
9		2487	990	3580											
10		2587	1090	3800											
15Z40	4	2314	600	1630	1695	845	250	200	4509						
	5	2439	725						4786						
	6	2564	850						5063						
	7	2689	975						5340						
	8	2814	1100						5617						
	9	2939	1225						5894						
	10	3064	1350						6171						
	11	3189	1475						6448						
12	3314	1600	6725												

RANGE OF OPERATION

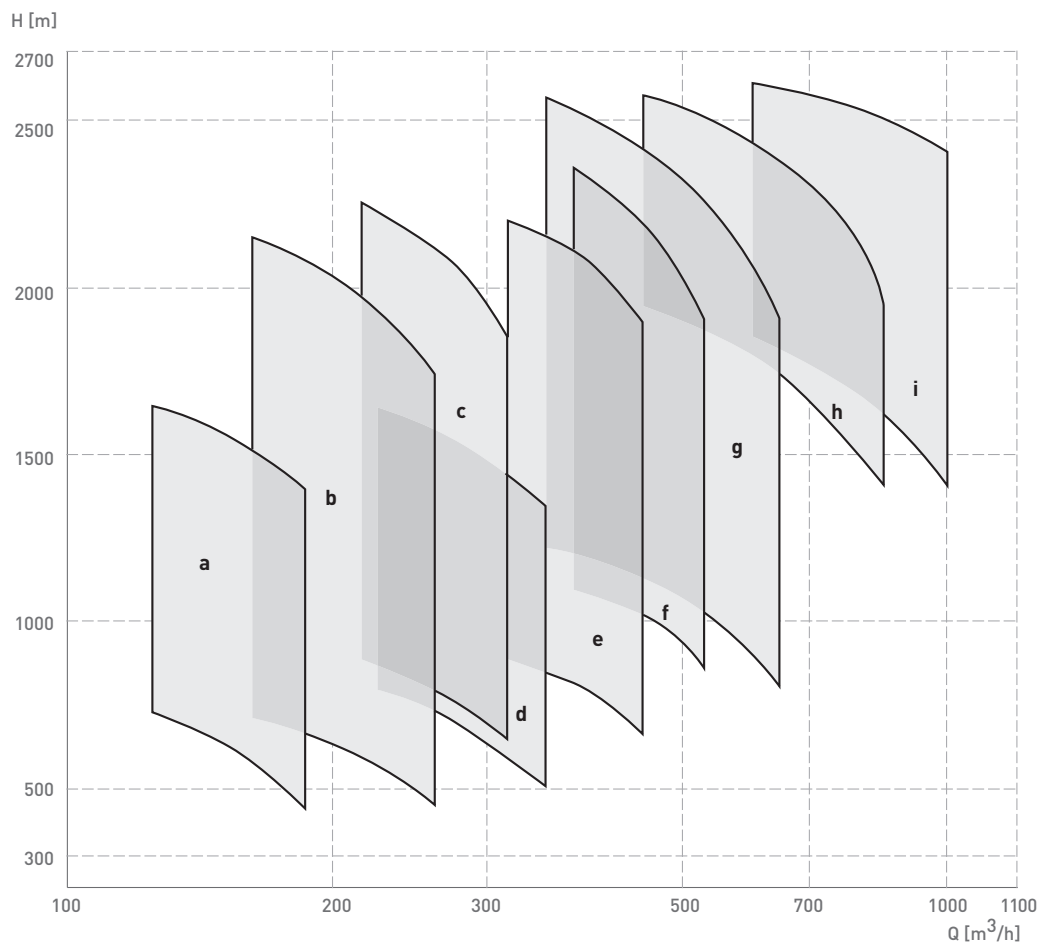

- a** -15Z28; $n = 3000 \text{ min}^{-1}$
- b** -15Z28; $n = 3920 \text{ min}^{-1}$
- c** -15Z28; $n = 4660 \text{ min}^{-1}$
- d** -15Z33; $n = 3000 \text{ min}^{-1}$
- e** -15Z33; $n = 3920 \text{ min}^{-1}$
- f** -15Z33; $n = 4660 \text{ min}^{-1}$
- g** -15Z40; $n = 3000 \text{ min}^{-1}$
- h** -15Z40; $n = 3920 \text{ min}^{-1}$
- i** -15Z40; $n = 4660 \text{ min}^{-1}$

NOMINAL PARAMETERS

Pump type	Number of stages	3000 [rpm]			3920 [rpm]			4660 [rpm]						
		Capacity Q [m ³ /h]	Head H [m]	Motor rated power P _s [kW]	Capacity Q [m ³ /h]	Head H [m]	Motor rated power P _s [kW]	Capacity Q [m ³ /h]	Head H [m]	Motor rated power P _s [kW]				
15Z28	3	160	-	-	225	570	630	275	780	1250				
	4		-	-		760	800		1040	1250				
	5		575	500		950	1000		1300	1600				
	6		690	630		1140	1250		1560	2000				
	7		805	630		1330	1600		1820	2000				
	8		920	800		1520	1600		2080	2500				
	9		1135	800		1710	2000		-	-				
	10		1250	1000		1900	2000		-	-				
	11		1365	1000		-	-		-	-				
	12		1480	1250		-	-		-	-				
	13		1595	1250		-	-		-	-				
	15Z33		3	300		-	-		390	765	1250	465	1080	2000
			4			600	800			1020	1600		1440	2500
5		750	1000		1275	2000	1800	3150						
6		900	1250		1530	2500	2160	4000						
7		1050	1250		1785	2500	-	-						
8		1200	1600		2040	3150	-	-						
9		1350	1600		-	-	-	-						
10		1500	2000		-	-	-	-						
15Z40		4	500		-	-	660	-		-	800		2000	5400
		5			1000	1900		1700		4000			2500	6600
	6	1200		2200	2040	4800		-	-					
	7	1400		2600	2380	5500		-	-					
	8	1600		2900	-	-		-	-					
	9	1800		3200	-	-		-	-					
	10	2000		3600	-	-		-	-					
	11	2200		3900	-	-		-	-					
	12	2400		4200	-	-		-	-					

The parameters are specified for clean water of density $\rho = 1000 \text{ kg/m}^3$ and temperature $T = 15^\circ\text{C}$.

SUPPLY PUMPS

YS

YS pumps are designed to handle
industrial and boiler water

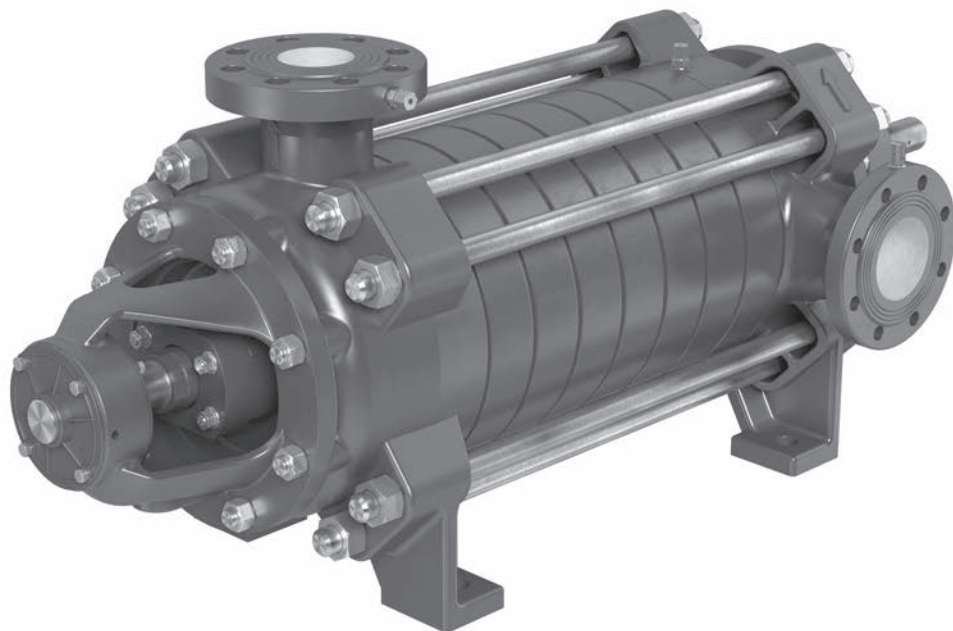

APPLICATION

YS pumps are designed to handle industrial and boiler water with temperature up to 150°C in all types of industrial installations requiring good suction properties.

Typical application include:

- boiler feeding
- pumping of condensate
- high-pressure washing

DESIGN

Stationary, horizontal multistage pumps with closed impellers arranged in series, with centrifugal and centripetal rotary vane guides. Pumps are equipped with different from the other first stage impeller, with enhanced anticavitation properties. The axial force is transmitted by the balance disc. In 25-80YS and 180YS pumps roller bearing are applied with solid lubricant that does not require refrigeration, while in 125-150YS pumps, shaft is supported on oil lubricated plain bearings.

In 25-80YS pumps suction flange depending on the version: for cold water pumps (up to 80°C) is directed to the side, and for the hot water pumps (up to 150°C) is directed vertically upwards. In 125-150YS pumps suction and discharge flange, always are directed vertically upwards. Pump casings can have applied mechanical seals or gland packing.

MATERIALS OF CONSTRUCTION

In standard materials version, 25-80YS and 180YS pumps are made of gray cast iron, and 125-150YS pumps are made of cast steel.

CROSS-SECTION / LIST OF PUMP PARTS FOR 25 - 80YS & 180YS PUMPS

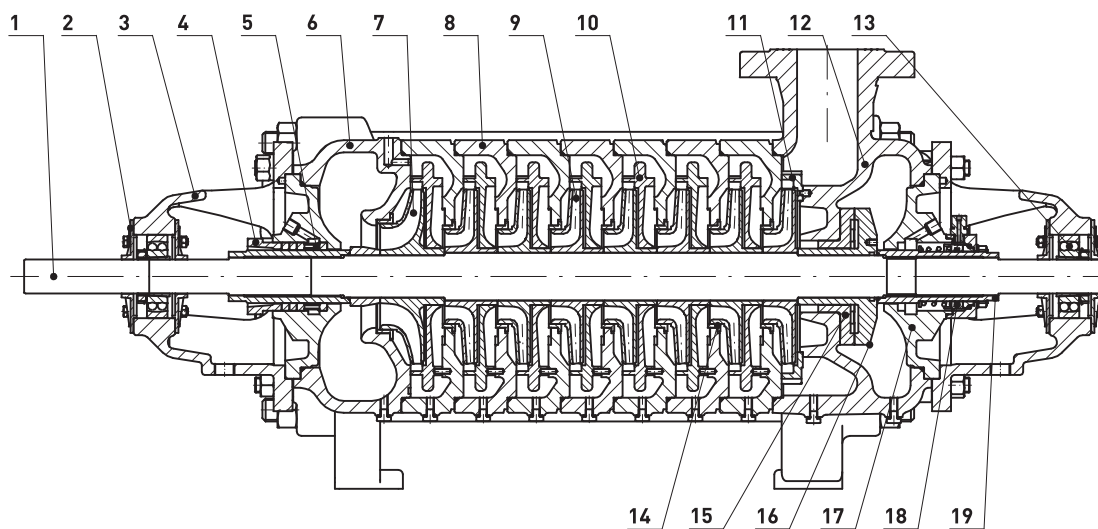

No.	Part name	No.	Part name
1	Shaft	11	Centrifugal guide
2	Thrust bearing cover	12	Discharge casing
3	Bearing housing	13	Radial bearing
4	Stuffing box	14	Sealing ring
5	Lantern ring	15	Anti-disc
6	Suction casing	16	Balance disk
7	1st stage impeller	17	Stuffing box casing
8	Stage casing	18	Gland packing or Mechanical seal
9	Impeller	19	Shaft protecting sleeve
10	Centrifugal-supply guide		

CROSS-SECTION / LIST OF PUMP PARTS FOR 125 - 150YS PUMPS

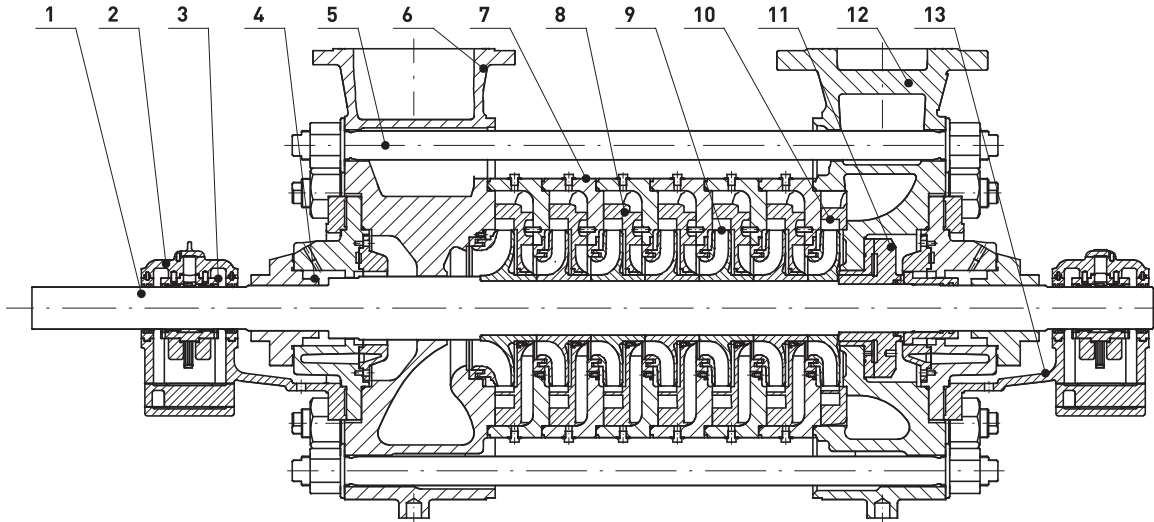

No.	Part name	No.	Part name
1	Shaft	8	Centrifugal-supply guide
2	Bearing housing cover	9	Impeller
3	Bearing bushing	10	Centrifugal guide
4	Mechanical seal	11	Balance disk
5	Tie bolt	12	Discharge casing
6	Suction casing	13	Bearing housing
7	Stage casing		

DIMENSIONS

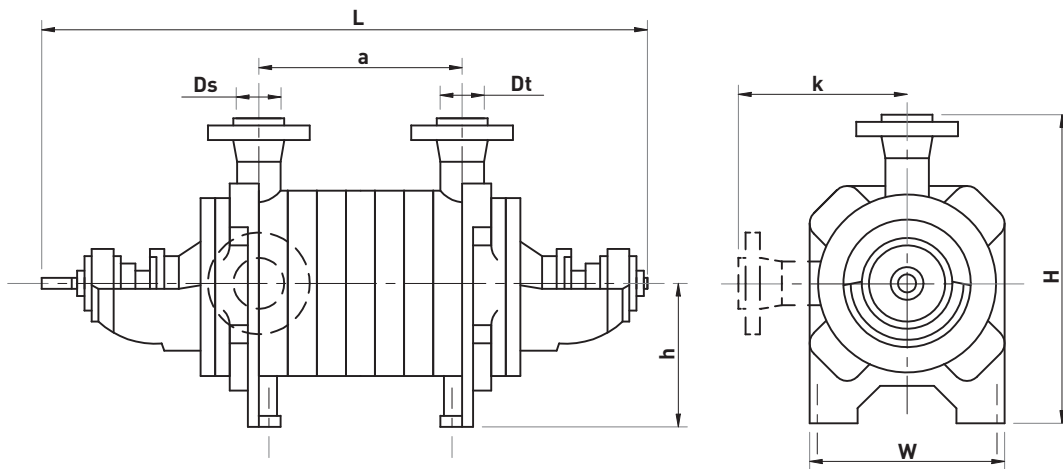

25 - 80 YS

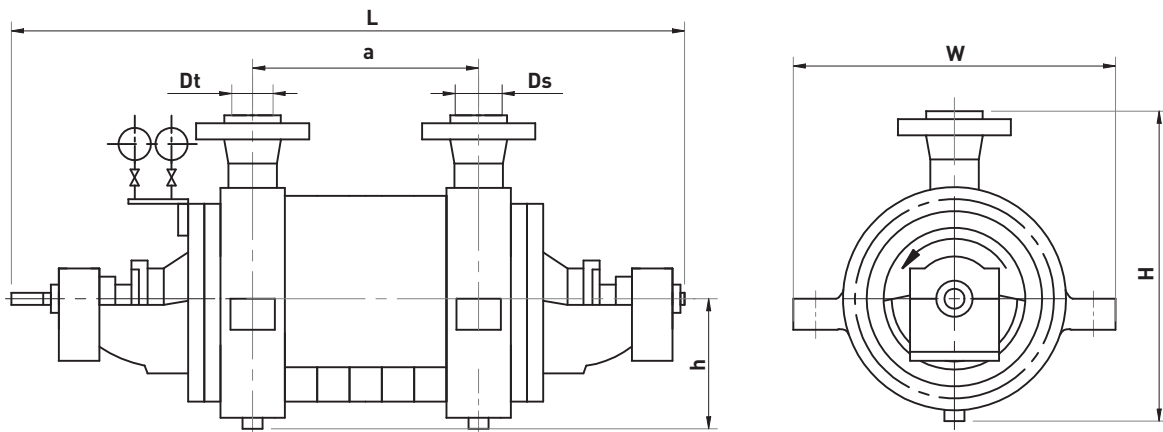

125 - 150 YS

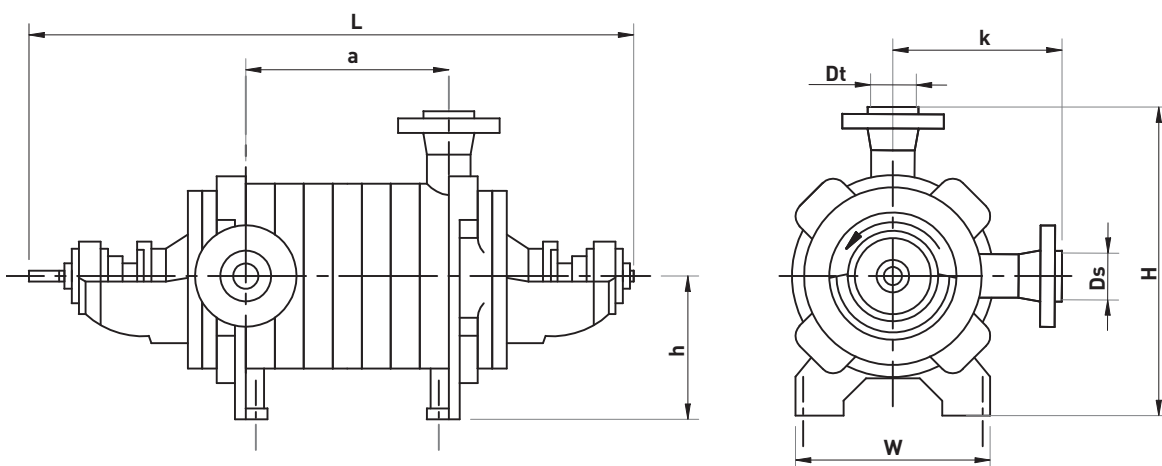

180 YS

Pump type	Number of stages	Dimensions [mm]							
		L	a	H	h	W	k	Ds	Dt
25YS	2	620	95	205	140	210	165	32	25
	3	655	130						
	4	690	165						
	5	725	200						
	6	760	235						
	7	795	270						
	8	830	305						
	9	865	340						
	10	900	375						
	11	935	410						
	12	970	445						
	13	1005	480						
	14	1040	515						
	15	1075	550						
	32YS	2	645						
3		685	160						
4		725	200						
5		765	240						
6		805	280						
7		845	320						
8		885	360						
9		925	400						
10		965	440						
11		1005	480						
12		1045	520						
13		1085	560						
14		1125	600						
15		1165	640						
40YS		2	711	134	420	200	300	220	50
	3	758	181						
	4	805	228						
	5	852	275						
	6	899	322						
	7	946	369						
	8	993	416						
	9	1040	463						
	10	1087	510						
	11	1134	557						
	12	1181	604						
	13	1228	651						
	14	1275	698						
	15	1322	745						
	50YS	2	820	165					
3		875	220						
4		930	275						
5		985	330						
6		1040	385						
7		1095	440						
8		1150	495						
9		1205	550						
10		1260	605						
11		1315	660						
12		1370	715						
13		1425	770						
14		1480	825						
15		1535	880						

Pump type	Number of stages	Dimensions [mm]							
		L	a	H	h	W	k	Ds	Dt
65YS	2	820	165	500	250	350	250	80	65
	3	875	220						
	4	930	275						
	5	985	330						
	6	1040	385						
	7	1095	440						
	8	1150	495						
	9	1205	550						
	10	1260	605						
	11	1315	660						
	12	1370	715						
	13	1425	770						
	14	1480	825						
	15	1535	880						
80YS	2	1010	210	580	280	420	300	100	80
	3	1080	280						
	4	1150	350						
	5	1220	420						
	6	1290	490						
	7	1360	560						
	8	1430	630						
	9	1500	700						
	10	1570	770						
	11	1640	840						
	12	1710	910						
	125YS	4	1480						
5		1560	515						
6		1640	595						
7		1720	675						
8		1800	755						
9		1880	835						
10		1960	915						
150YS	4	1590	507	778	348	890	-	200	150
	5	1680	597						
	6	1770	687						
	7	1860	777						
	8	1950	867						
	9	2040	957						
	10	2130	1047						
180YS	2	1125	270	715	340	625	375	150	150
	3	1230	375						
	4	1335	480						
	5	1440	585						
	6	1545	690						
	7	1650	795						
	8	1755	900						
	9	1860	1005						
	10	1965	1110						

RANGE OF OPERATION

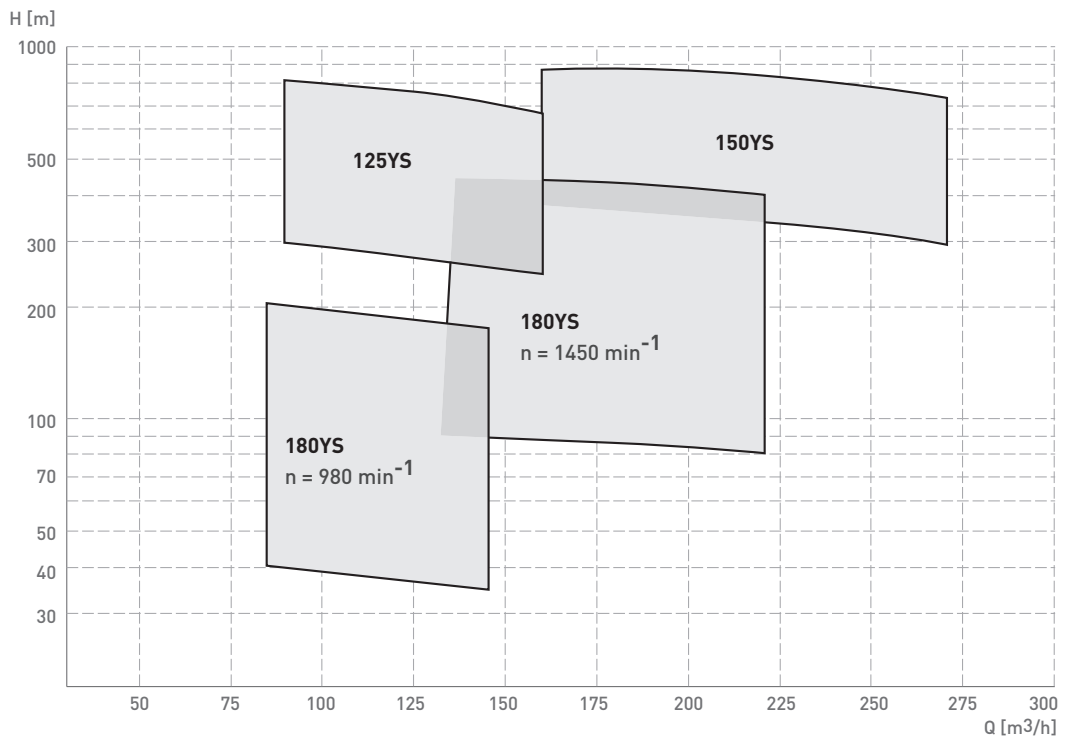
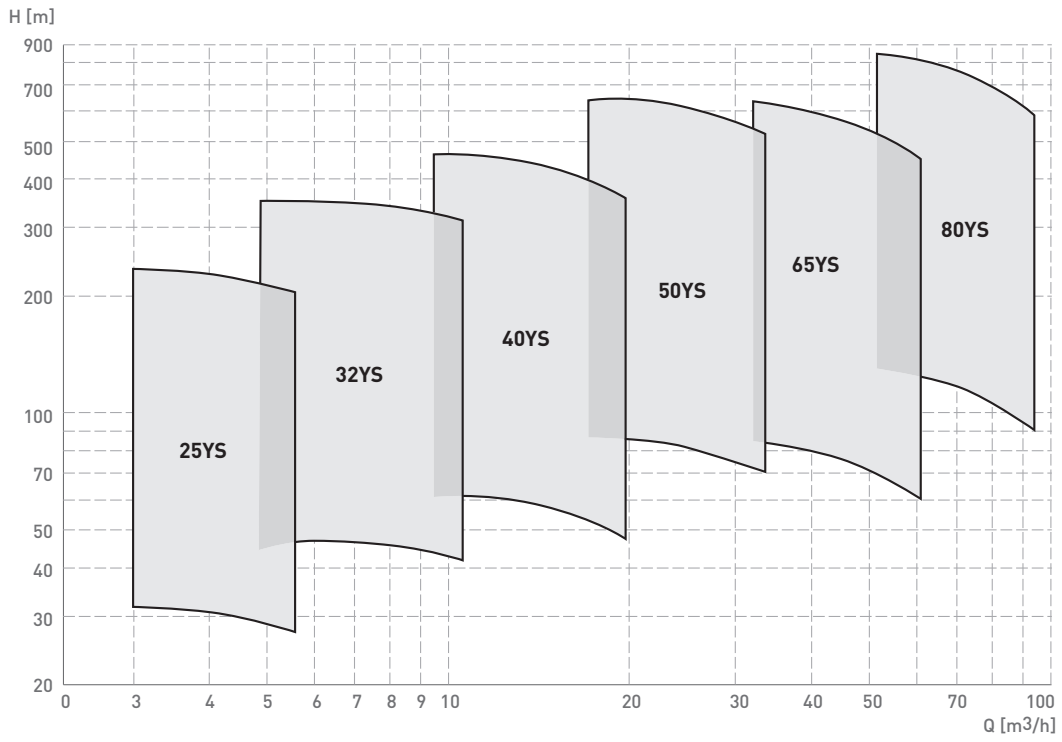

NOMINAL PARAMETERS

Pump type	Number of stages	Capacity Q [m ³ /h]	Head H [m]	Rotation speed n [rpm]	Shaft power P [kW]	Weight m [kg]
25YS	2	4,5	30	3000	0,9	52,6
	3		45		1,4	57,8
	4		60		1,8	63
	5		75		2,3	68,2
	6		90		2,8	73,1
	7		105		3,2	78,6
	8		120		3,7	83,8
	9		135		4,1	89,4
	10		150		4,6	94,2
	11		165		5,1	99,4
	12		180		5,5	104,6
	13		195		6,0	109,8
	14		210		6,4	115
	15		225		6,9	120,2
	32YS		2		8,5	44
3		66	3,5	72		
4		88	4,6	80		
5		110	5,8	87,5		
6		132	6,9	95		
7		154	8,1	103		
8		176	9,3	110,5		
9		198	10,4	118		
10		220	11,6	126		
11		242	12,7	134		
12		264	13,9	141,5		
13		286	15,1	149		
14		308	16,2	157		
15		330	17,4	164,5		
40YS		2	16	54		3000
	3	81		6,3	119,8	
	4	108		8,4	130,5	
	5	135		10,5	142	
	6	162		12,6	153	
	7	189		14,7	164,5	
	8	216		16,8	176	
	9	243		18,9	187	
	10	270		21,0	198,5	
	11	297		23,1	210	
	12	324		25,2	221	
	13	351		27,3	232,5	
	14	378		29,4	243,5	
	15	405		31,5	255	
	50YS	2		27	80	
3		120	16,8		177	
4		160	22,4		194	
5		200	28,0		210	
6		240	33,6		227	
7		280	39,2		244	
8		320	44,8		261	
9		360	50,5		278	
10		400	56,1		295	
11		440	61,7		311	
12		480	67,3		328	
13		520	72,9		345	
14		560	78,5		362	
15		600	84,1		378	



Pump type	Number of stages	Capacity Q [m ³ /h]	Head H [m]	Rotation speed n [rpm]	Shaft power P [kW]	Weight m [kg]
65YS	2	45	80	3000	14,4	162
	3		120		21,6	181
	4		160		28,9	199
	5		200		36,1	217
	6		240		43,3	235
	7		280		50,5	253
	8		320		57,7	272
	9		360		64,9	290
	10		400		72,1	308
	11		440		79,3	326
	12		480		86,6	344
	13		520		93,8	363
	14		560		101,0	381
	15		600		108,2	399
	80YS		2		75	120
3		180	53,9	319		
4		240	71,8	352		
5		300	89,8	385		
6		360	107,7	418		
7		420	125,7	451		
8		480	143,6	484		
9		540	161,6	517		
10		600	179,5	550		
11		660	197,5	583		
12		720	215,4	616		
125YS		4	130	280		3000
	5	350		169,8	908	
	6	420		203,8	958	
	7	490		237,8	1008	
	8	560		271,8	1058	
	9	630		305,7	1108	
	10	700		339,7	1158	
150YS	4	230	320	3000	269,2	1174
	5		400		336,5	1245
	6		480		403,8	1316
	7		560		471,1	1387
	8		640		538,4	1458
	9		720		605,7	1529
180YS	2	180	85	1500	55,6	967
	3		128		83,7	1020
	4		170		111,2	1080
	5		212		138,6	1132
	6		255		166,8	1185
	7		297		194,2	1240
	8		340		222,4	1295
	9		383		250,5	1350
	10		425		278,0	1405
	180YS		2		120	37
3		56	24,4	1020		
4		75	32,7	1080		
5		93	40,5	1132		
6		112	48,8	1185		
7		131	57,2	1240		
8		150	65,4	1295		
9		168	73,2	1350		
10		187	81,5	1405		

The parameters are specified for clean water of density $\rho = 1000 \text{ kg/m}^3$ and temperature $T = 15^\circ\text{C}$.

CONDENSATE PUMPS

K and KW pumps are designed as multi-stage vertical pumps for pumping condensate and clean water in thermal power plants

K
WK



APPLICATION

K and WK type pumps are designed as condensate extraction pumps for thermal power plants. Due to their good suction properties they can be also applied in any other cases when extremely low NPSH is available.

DESIGN

Vertical, multistage pumps installed in a can. The suction and delivery flanges are arranged horizontally on opposite sides of the pumps. Water from the suction flange is directed to the bottom of the can in order to provide an increased suction head. The first stage impeller, installed on the lower end of the vertical shaft is of special design with improved suction properties. In larger pump sizes a double- suction first stage impeller is applied. The radial bearings submerged in water are slide type and the axial thrust bearing is roller type, oil lubricated. Mechanical seal is applied.

MATERIALS OF CONSTRUCTION

The impellers and diffusers are made of stainless chromium cast steel.

CROSS-SECTION / LIST OF PUMP PARTS

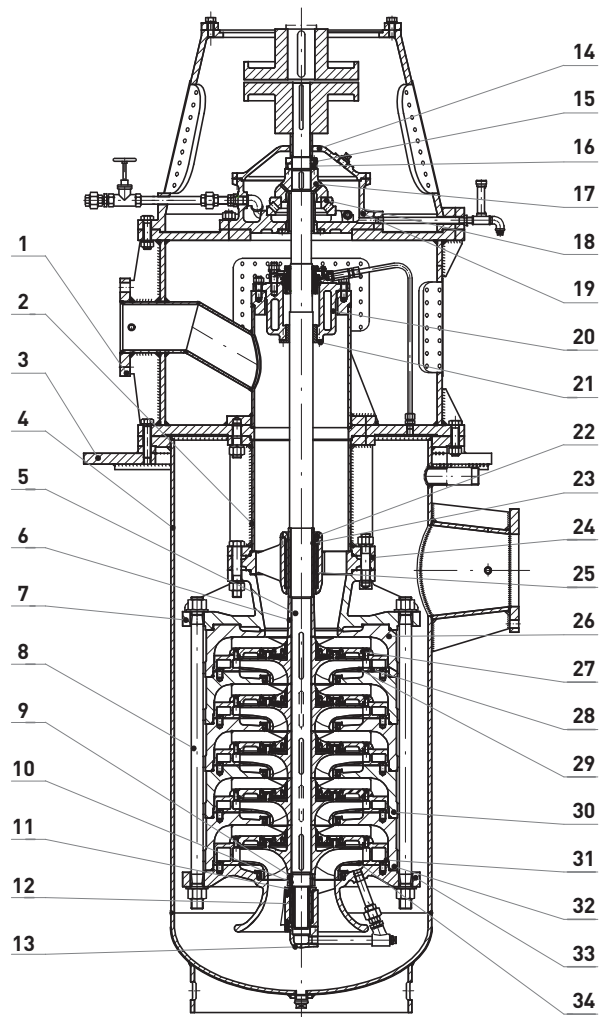

No.	Part name	No.	Part name	No.	Part name
1	Discharge flange	13	Cover	25	Bushing
2	Discharge column	14	Thrust bearing cover	26	2nd stage casing
3	Base plate	15	Slotted nut	27	Guide vane
4	Can	16	Slotted nut	28	Radial diffuser
5	Shaft	17	Thrust plate	29	Impeller
6	Spacer sleeve	18	Rolling bearing	30	Stage casing
7	Casing	19	Bearing housing	31	Radial diffuser1
8	Tie bolt	20	Stuffing box casing	32	1st stage casing
9	Shaft nut	21	Sealing sleeve	33	Inlet funnel
10	Shaft nut	22	Ring	34	Impeller 1
11	Retainer ring	23	Bushing bearing		
12	Bushing	24	Bearing insert		

DIMENSIONS

10K22, 12K28

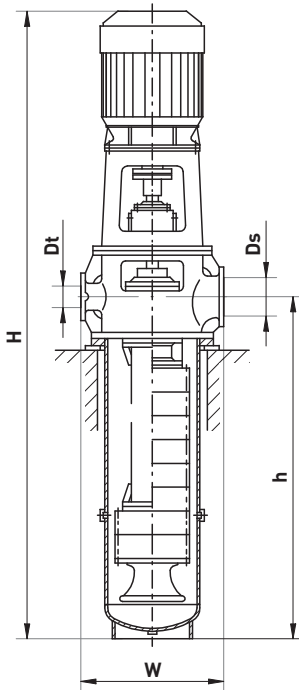

10K34, 15K34, 20K37, 25K41

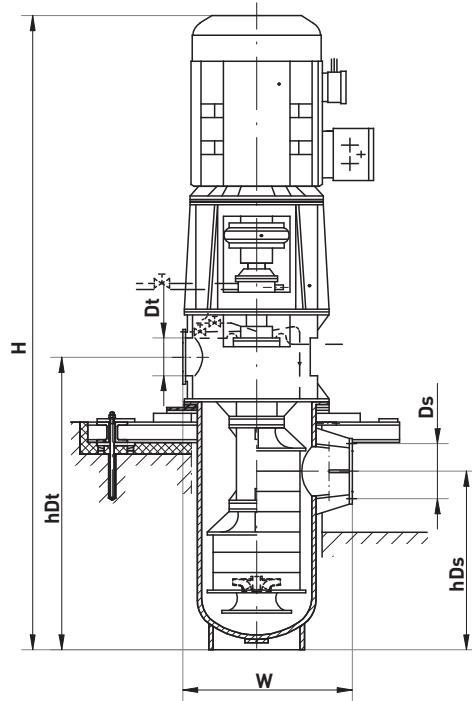

30WK45

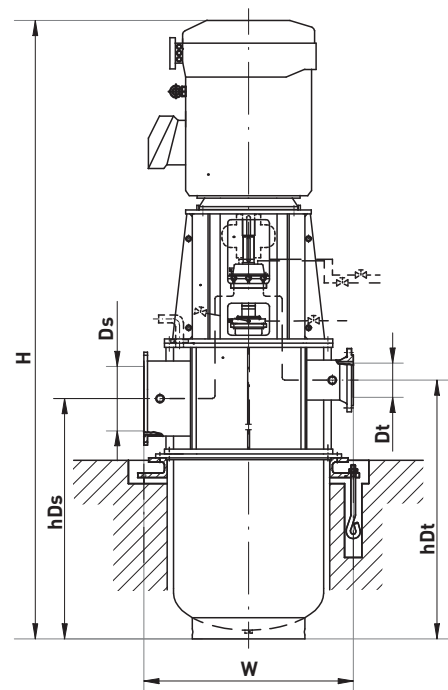

Pump types	Nuner of stages	Dimensions [mm]						
		H	h	hDs	hDt	W	Ds	Dt
10K22A	2	2446	1415	-	-	700	150	100
	3	2542	1415					
	4	2586	1415					
	5	2722	1525					
	6	2612	1415					
	7	2722	1525					
10K22B	2	2512	1415	-	-	700	150	100
	3	2586	1415					
	4	2612	1415					
	5	2786	1525					
	6	2741	1415					
	7	2851	1525					
12K28	2	2615	1275	-	-	850	200	125
	3	2615	1275					
	4	2640	1275					
	5	2895	1390					
	6	3205	1505					
	7	3520	1620					
12K34	2	3380	-	1220	1890	1100	200	125
	3	1960						
	4	2020						
	5	2190						
	6	2190						

Pump types	Nuner of stages	Dimensions [mm]						
		H	h	hDs	hDt	W	Ds	Dt
15K34	2	3550	-	1220	1890	1100	250	150
	3	1960						
	4	2050						
	5	2190						
	6	2560						
20K37	3	3760	-	1300	2080	1150	300	200
	4	2010						
	5	2285						
	6	2285						
	7	2285						
20K37A	2	3800	-	1350	2080	1150	350	200
	3	2170						
	4	2170						
	5	2540						
	6	2580						
25K41	2	3725	-	1125	2005	1250	500	250
	3	2170						
	4	2355						
	5	2355						
30WK45	2	5274	-	2050	2200	1700	600	300
	3	3893						
	4	4154						

RANGE OF OPERATION

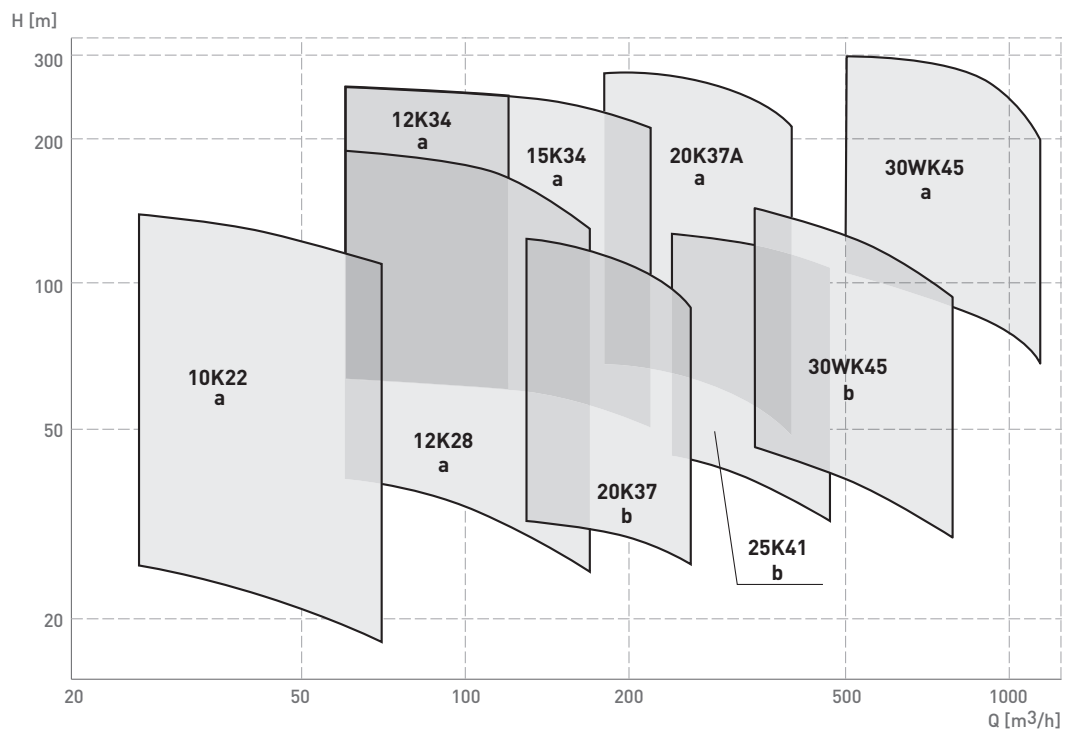

a - 1470 min⁻¹

b - 960 min⁻¹

NOMINAL PARAMETERS

Pump type	Number of stages	Capacity Q [m³/h]	Head H [m]	Motor rated power P _s [kW]	Rotation speed n [rpm]	Weight m [kg]
10K22A	2	36	30	5,5 / 7,5	1500	764
	3		45	7,5 / 11		885
	4		60	11 / 15		961
	5		75	15 / 18,5		1066
	6		90	18,5		1095
	7		105	18,5 / 22		1194
	8		120	22		1273
10K22B	2	60	30	11	1500	826
	3		45	15		895
	4		60	18,5		983
	5		75	22		1084
	6		90	30		1196
	7		105	20		1286
	8		120	37		1403
12K28	2	100 130*	44	18,5 / 22	1500	1139
	3		66	22 / 30 / 37		1328
	4		88	37 / 45		1411
	5		110	45 / 55		1592
	6		132	55 / 75		1841
	7		154	75		2013
15K34	2	180	72	45 / 55	1500	200
	3		108	75		2240
	4		144	90 / 110		2495
	5		180	110 / 132		2670
	6		216	132 / 160		2770
20K37	3	240	51	45 / 55	1000	2849
	4		68	55 / 75		3368
	5		85	75 / 90		3591
	6		102	110		3738
	7		119	132		3936
20K37A	2	300	80	90	1500	2985
	3		120	132		2695
	4		160	160 / 200		3560
	5		200	200 / 250		3870
	6		240	250 / 320		4450
25K41	2	360	46	55 / 75	1000	3470
	3		69	75 / 90		3695
	4		92	110 / 132		4100
	5		115	132 / 160		4860
	6		140	160 / 200		5470
30WK45	2	900	112,5	320 / 400	1500	8330
	3		180	500 / 630		9100
	4		260	800 / 1000		9470
30WK45	2	600	50	110 / 132	1000	8330
	3		80	160 / 200		9100
	4		116	250 / 320		9470

The parameters are specified for clean water of density $\rho = 1000 \text{ kg/m}^3$ and temperature $T = 15^\circ\text{C}$.

COOLING WATER PUMPS

D

D range pumps are designed as mixed-flow vertical pumps, either single-stage or multi-stage with either closed or open impellers and vane diffusers

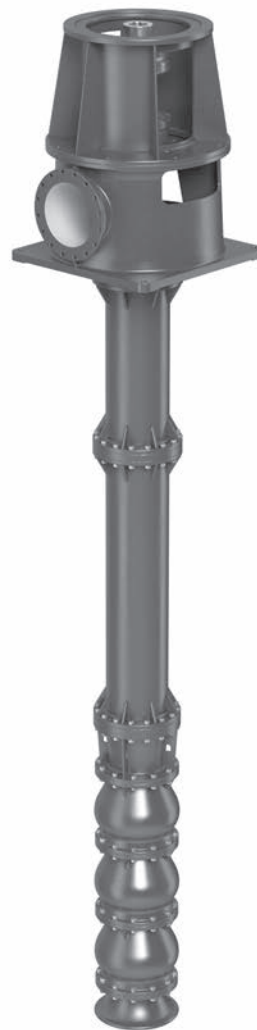

APPLICATION

D type pumps are typically applied at water intakes and as cooling water pumps in power plants and other industrial installations. They are also applicable in any other cases when high capacity is required at relatively low head.

DESIGN

D-type pumps are vertical, mixed flow turbine pumps. They are available in many versions both single and multistage. The pump inlet is at the bottom of the pump. Impellers are assembled on the end of the vertical shaft. Water flows through the vane diffuser and then through the vertical column along the shaft with radial bearings lubricated by the pumped water. The delivery flange is directed horizontally over the floor on which the pump is supported. The axial bearing mounted over the elbow leading to the delivery flange is a roller type for smaller sizes and Mitchell type for bigger pumps. The axial bearings are oil lubricated and cooled by water if necessary. For smaller pumps the motor is supported on the pump, while for biggest units it is assembled on a separate floor.

MATERIALS OF CONSTRUCTION

The impellers are made of bronze or stainless cast steel. The other elements in standard version are made of cast iron or steel.

CROSS-SECTION / LIST OF PUMP PARTS

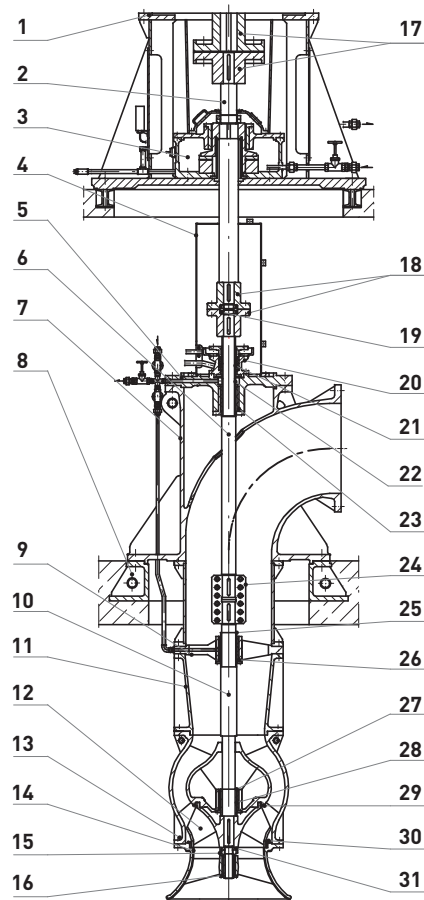

No.	Part name	No.	Part name
1	Motor support	17	Elastic coupling
2	Upper shaft	18	Rigid coupling
3	Thrust bearing subassembly	19	Slotted nut
4	Coupling guard	20	Gland seal
5	Elbow cover	21	Gland sleeve
6	Intermediary shaft	22	Slide bearing
7	Discharge elbow	23	Bushing
8	Ceiling ring	24	Split-muff coupling
9	Bearing insert	25	Slide bearing
10	Lower shaft	26	Bushing
11	Vaneless diffuser	27	Bushing bearing
12	Impeller	28	Bushing
13	Vane diffuser	29	Sealing ring
14	Inlet bell	30	Sealing ring
15	Bushing bearing with thread	31	Impeller nut
16	Bush		

DIMENSIONS

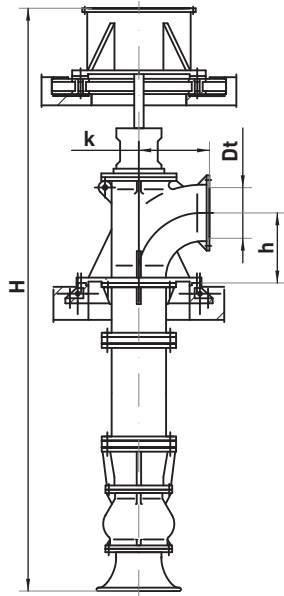

Pump type size	Dimensions [mm]			
	H	h	k	Dt
15D	2950÷27765	300	300	150
20D	3050÷27350	350	350	200
25D	3170÷26450	350	350	250
30D	3260÷26660	400	400	300
35D	3190÷23770	400	400	350
40D	3470÷22820	450	450	400
50D	3970÷21000	500	500	500
60D	4350÷18790	550	550	600
80D	4960÷20330	600	600	800
90D	5742÷9880	800	800	900
100D	6020÷8452	900	1000	1000
120D	6450÷7850	1050	1100	1200
140D	6650÷9685	990	1250	1400
160D	7915÷10315	1250	1250	1600
180D	8966÷11366	1350	1500	1800

RANGE OF OPERATION

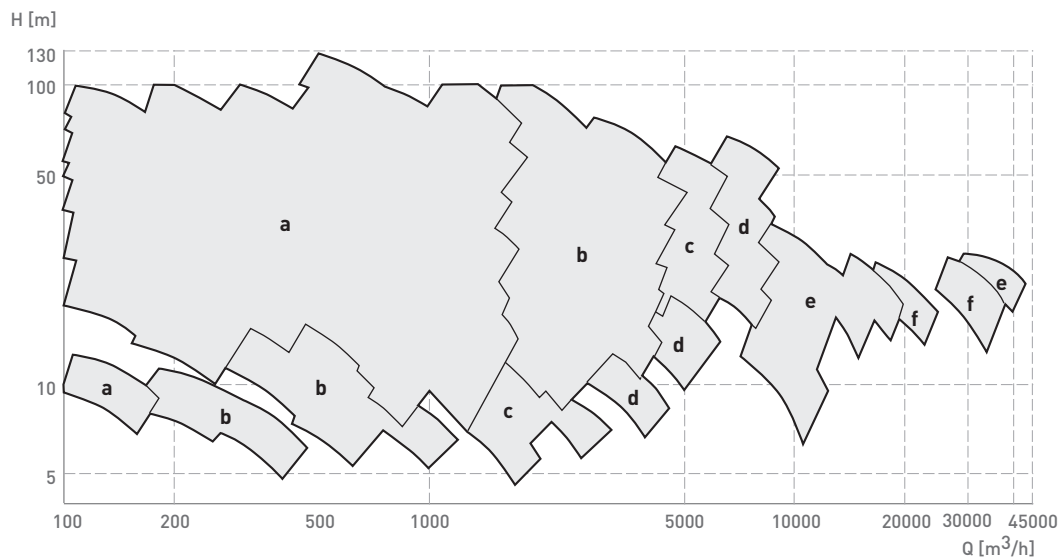

a – 1470 min⁻¹ **d** – 590 min⁻¹
b – 980 min⁻¹ **e** – 490 min⁻¹
c – 725 min⁻¹ **f** – 360 min⁻¹

NOMINAL PARAMETERS

Pump hydraulic type size x Number of stages	Capacity Q [m ³ /h]	Head H [m]	Rotation speed n [rpm]	Motor rated power P _s [kW]
15D17-2	190	10	1500	11
15D17-2x2	190	20	1500	18,5
15D17-2x3	190	30	1500	30
15D17-2x4	190	40	1500	37
15D17-2x5	190	50	1500	45
15D17-2x6	190	60	1500	55
15D17-2x7	190	70	1500	55
15D17-2x8	190	80	1500	75
20D15-2	250	17,5	1500	22
20D15-2x2	250	35	1500	45
20D15-2x3	250	52,5	1500	75
20D15-2x4	250	70	1500	90
20D15-2x5	250	87,5	1500	110
25D17-2	400	22	1500	37
25D17-2x2	400	44	1500	75
25D17-2x3	400	66	1500	110
25D17-2x4	400	88	1500	160
25D17-3	265	10	1000	15
30D17-2	640	30	1500	90
30D17-2x2	640	60	1500	160
30D17-2x3	640	90	1500	250
30D17-2x4	640	112	1500	320
30D17-3	400	13	1000	30
30D22-2	620	19	1500	55
30D22-2x2	620	38	1500	110
30D22-3	400	7,5	1000	15
35D22-2	1000	28	1500	110
35D22-2x2	1000	56	1500	250
35D22-2x3	1000	84	1500	400
35D22-3	630	11	1000	37
35D30-2	950	20	1500	90
35D30-2x2	950	40	1500	160
35D30-3	630	9	1000	30
35D40-2	800	12	1500	45
40D22-2	1500	35	1500	250
40D22-2x2	1500	70	1500	500
40D22-2x3	1500	96	1500	630
40D30-2	1500	24	1500	160
40D30-2x2	1500	48	1500	315
40D40-2	1575	17	1500	110
40D40-3	1050	7,5	1000	37
40D32-3	1250	12	1000	75
50D22a-3	2250	30	1000	315

Pump hydraulic type size x Number of stages	Capacity Q [m ³ /h]	Head H [m]	Rotation speed n [rpm]	Motor rated power P _s [kW]
50D22a-3x2	2250	60	1000	500
50D22a-3x3	2250	90	1000	800
50D30-3	2250	20	1000	200
50D30-3x2	2250	40	1000	400
50D30-4	1700	10,5	750	90
50D40-3	2400	14	1000	160
50D40-4	1800	7,5	750	75
60D20-3	4800	53	1000	900
60D22-3	3600	35	1000	500
60D22-3x2	3600	70	1000	1000
60D26-3	5750	46	1000	1000
60D26-4	4250	26	750	400
60D30-3	3600	23	1000	400
60D30-3x2	3600	48	1000	710
60D40-3	3600	18	1000	250
60D40-4	2700	8,5	750	90
80D22-4	6000	27	750	630
80D22-4x2	6000	54	750	1250
80D25-4	6000	38	750	1000
80D30-4	5250	22	750	500
80D31-5	5500	17,5	600	400
80D32-5	4750	15	600	315
80D32-6	4000	10	500	160
90D22-5	7500	30	600	1000
90D30-5	7500	22,5	600	800
90D30-5x2	7500	45	600	1600
100D22-6	10500	30	500	1250
100D30-6	10500	21,5	500	1000
100D40-6	9700	14,5	500	630
120D30-6	13500	24	500	1250
120D40-6	13500	20	500	1000
140D40-6	17500	24	500	1600
160D30-8	22000	22	375	1800
180D30-8	37500	24	375	3200
180D40-8	32000	22	375	2500

The parameters are specified for clean water of density $\rho = 1000 \text{ kg/m}^3$ and temperature $T = 15^\circ\text{C}$.

COOLING WATER PUMPS

P

P pumps are designed as vertical
single-stage propeller pumps
with a vane diffusers



APPLICATION

P type pumps are applicable in any case when high capacity is required at low head. Typically P type pumps are applied as cooling water pumps in power plants with external source of cooling water and in melioration pumping stations.

DESIGN

P-type pumps are vertical, axial flow propeller pumps. The pump inlet is at the bottom of the pump. Impellers are assembled on the end of the vertical shaft. Water flows through the vane diffuser and then through the vertical column along the shaft with radial bearings lubricated by the pumped water. The delivery flange is directed horizontally over the floor on which the pump is supported. The axial bearing mounted over the elbow leading to the delivery flange is a roller type for smaller sizes and Mitchell type for bigger pumps. The axial bearings are oil lubricated and cooled by water if necessary. For smaller pumps the motor is supported on the pump, while for biggest units it is assembled on a separate floor.

MATERIALS OF CONSTRUCTION

The impellers are made of bronze or stainless cast steel. The other elements in standard version are made of cast iron or steel.

CROSS-SECTION / LIST OF PUMP PARTS

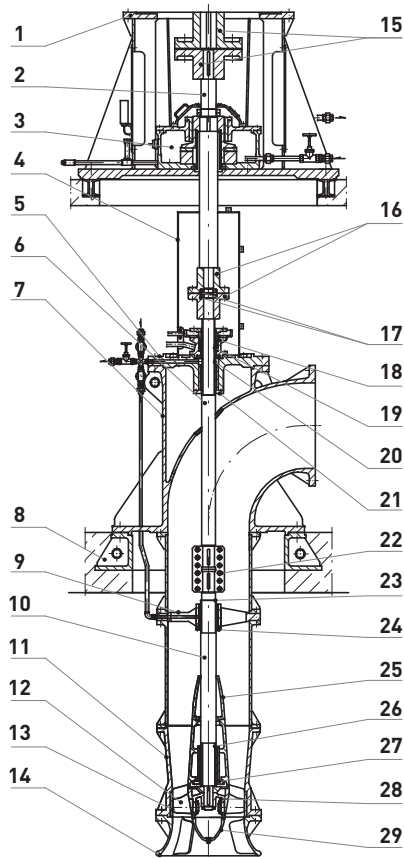

No.	Part name
1	Motor support
2	Upper shaft
3	Thrust bearing subassembly
4	Coupling guard
5	Elbow cover
6	Intermediate shaft
7	Discharge elbow
8	Ceiling ring
9	Bearing insert
10	Lower shaft
11	Diffuser
12	Impeller vane
13	Diffuser layer
14	Inlet bell
15	Elastic coupling
16	Rigid coupling
17	Slotted nut
18	Gland seal
19	Gland sleeve
20	Slide bearing
21	Bushing
22	Split-muff coupling
23	Slide bearing
24	Bushing
25	Fairwater cone
26	Slide bearing
27	Bushing
28	Impeller hub
29	Impeller cup

DIMENSIONS

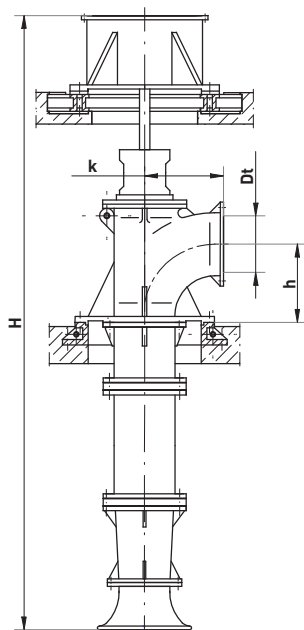

Pump type	Dimensions [mm]			
	H	h	k	Dt
25P	2350÷5240	350	350	250
30P	2540÷5560	400	400	300
40P	2700÷6950	500	500	400
50P	2900÷8500	550	550	500
60P	3200÷9170	600	600	600
80P	3770÷10150	800	800	800
100P	5165÷11895	900	900	1000
120P	5600÷12130	1000	1000	1200
160P	7150÷14750	1250	1250	1600
180P	7550÷15485	1350	1500	1800

RANGE OF OPERATION

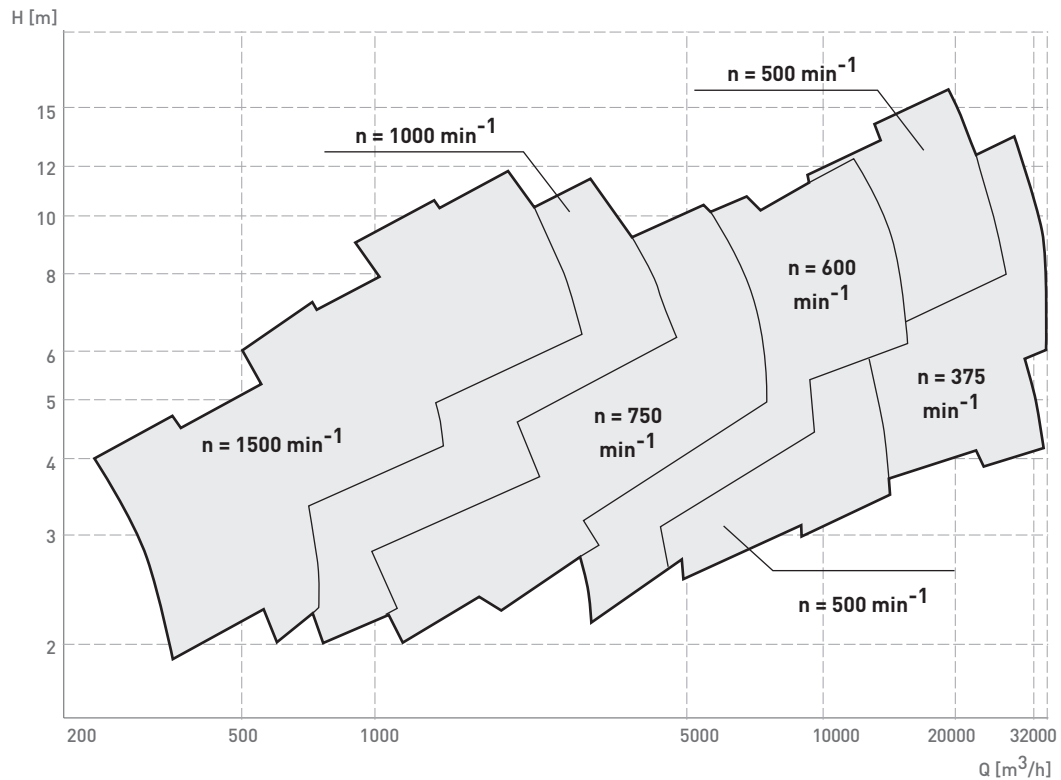

NOMINAL PARAMETERS

Pump hydraulic type size - Number of stages	Capacity Q [m ³ /h]	Head H [m]	Rotation speed n [rpm]	Motor rated power P_s [kW]
25P21-2	420	4	1500	7,5
30P23-2	650	4,5	1500	15
30P19-2	900	5,8	1500	22
40P23-2	1250	6	1500	37
40P21-2	1400	9,2	1500	55
40P21-3	900	4,2	1000	18,5
40P19-2	2100	9,6	1500	90
50P17-3	2100	5,7	1000	45
50P17-4	1600	3,2	750	22
60P23-4	2700	4	750	45
60P18-3	3520	9,5	1000	160
60P18-4	2900	5,7	750	75
80P23-5	3800	4,5	600	75
80P17-4	6100	9,5	750	250
80P17-5	4900	5,8	600	125
100P17-5	8500	8	600	320
100P17-6	7000	5,5	500	160
120P23-5	13200	9	600	500
120P23-6	11200	6	500	320
160P19-6	21200	10,5	500	1000
160P19-8	17000	5,5	375	400
180P19-8	32000	9,5	375	1250
180P27-8	27000	5,5	375	630

The parameters are specified for clean water of density $\rho = 1000 \text{ kg/m}^3$ and temperature $T = 15^\circ\text{C}$.

HOT WATER PUMPS

B and BV pumps are designed as horizontal
splitcasing centrifugal, double suction pumps
with closed impellers

B BV



APPLICATION

The B and BV pumps are designed to handle hot, clean and slightly contaminated water. They can be applied in water supply systems, industrial cooling systems, and, for the ability to pump hot water, in district heating and power plants.

DESIGN

Stationary, horizontal, double suction, horizontally split pumps. The suction and delivery flanges are arranged horizontally in-line. The upper part of the casing can be lifted and the entire rotating assembly can be taken out for repair without disconnecting the pump from the pipelines. The oil-lubricated roller bearings and the mechanical seals installed on both sides of the shaft are equipped with cooling chambers, so the pumps are able to handle hot fluids.

BV pumps are a vertical version of B pumps. They are based on the same hydraulics.

MATERIALS OF CONSTRUCTION

The casings are made of cast iron or, for higher heads, of cast steel. The impellers are of cast iron or stainless chromium cast steel.

CROSS-SECTION / LIST OF B PUMP PARTS

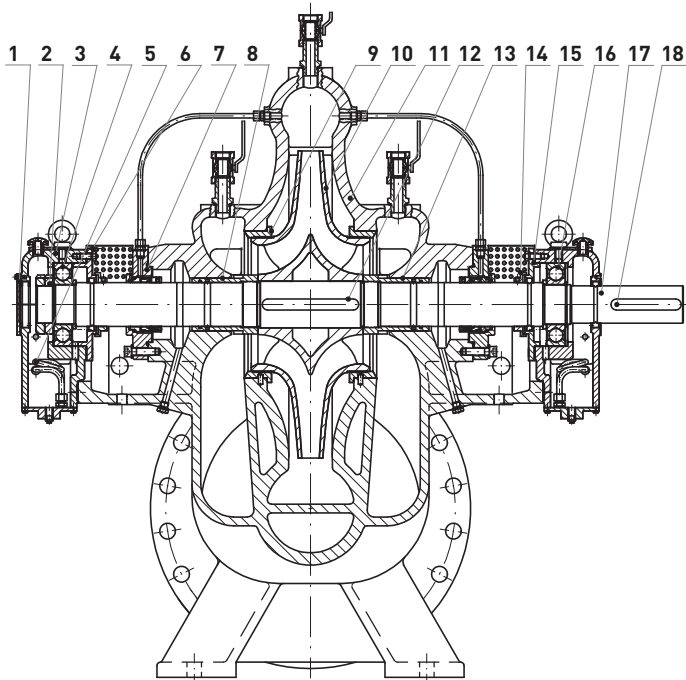

No.	Part name
1	Bearing housing cover
2	Nut
3	Bearing housing
4	Bearing
5	Cooler
6	Thrust Thrust bearing cover
7	Mechanical seal
8	Gland seal
9	Seal ring
10	Impeller
11	Casing
12	Key groove
13	Left gland sleeve
14	Expeller
15	Radial bearing cover
16	Bearing
17	Shaft
18	Key groove

CROSS-SECTION / LIST OF BV PUMP PARTS

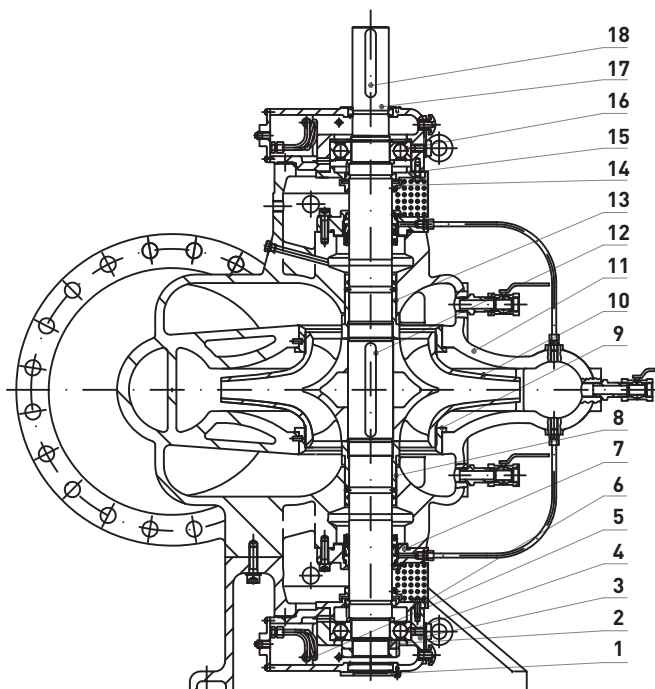

No.	Part name
1	Bearing housing cover
2	Nut
3	Bearing housing
4	Bearing
5	Cooler
6	Thrust Thrust bearing cover
7	Mechanical seal
8	Gland seal
9	Seal ring
10	Impeller
11	Casing
12	Key groove
13	Left gland sleeve
14	Expeller
15	Radial bearing cover
16	Bearing
17	Shaft
18	Key groove

DIMENSIONS

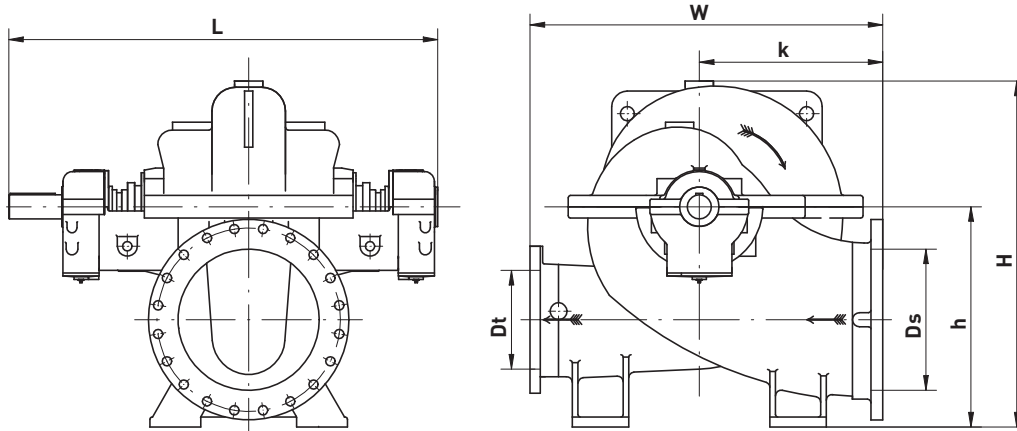

Pump type	Dimensions [mm]							Weight m [kg]
	L	W	k	H	h	Ds	Dt	
20B47	1060	1000	500	930	560	250	200	1150
25B32	1165	870	470	910	580	350	250	850
25B35	1040	950	550	805	520	300	250	730
25B50	1380	970	500	975	610	350	250	890
30B30	1165	870	470	875	560	350	300	880
30B46	1215	1200	600	1030	630	350	300	1135
30B50	1380	1200	600	1135	720	400	300	1250
30B52	1415	1150	500	1015	630	350	300	1170
30B70	1520	1250	650	1290	800	400	300	1680
35B35	1520	1150	600	940	600	400	350	1170
35B40	1520	1210	650	1215	780	500	350	1500
35B50	1520	1250	650	1225	780	500	350	1520
35B63	1520	1250	650	1340	850	500	350	1730
40B36	1655	1230	680	1115	735	500	400	2100
40B40	1520	1350	750	1295	820	500	400	1720
40B49	1336	1600	800	1290	800	450	400	2355
40B50	1520	1310	710	1370	860	500	400	1750
40B61A	1960	1680	830	1310	800	500	400	2860
40B63	1584	1760	880	1345	800	500	400	2660
40B80	2080	1800	900	1540	950	600	400	3920
50B40	1785	1560	850	1490	950	600	500	2470
50B50	1820	1650	900	1490	960	600	500	2880
50B50D	1615	1750	750	1290	800	600	500	2750
50B50F	1615	1750	750	1290	800	600	500	1750
50B52A	1060	1930	930	1250	850	600	500	2800
50B63	1785	1700	850	1520	950	600	500	2780
50B80	2015	2000	1000	1770	1100	700	500	4015
60B63A	2015	1900	950	1670	1050	700	600	3200
70B90	2800	2900	1300	2700	1800	900	700	~5500

RANGE OF OPERATION

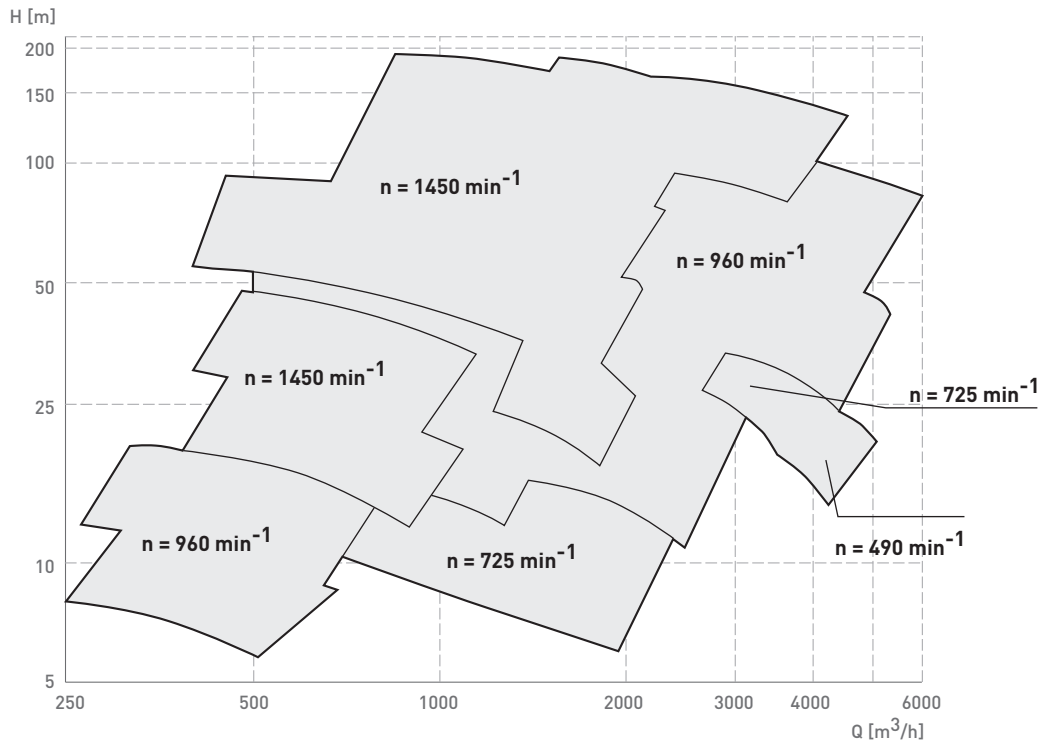

NOMINAL PARAMETERS

Pump type*	725 [rpm] /(490 [rpm] 70B90 only)			960 [rpm]			1450 [rpm]		
	Capacity Q [m ³ /h]	Head H [m]	Shaft power P [kW]	Capacity Q [m ³ /h]	Head H [m]	Shaft power P [kW]	Capacity Q [m ³ /h]	Head H [m]	Shaft power P [kW]
20B47	-	-	-	343	28	35	510	62	116
25B32	-	-	-	600	18,5	38	900	42	123
25B35	-	-	-	400	15	19	600	34	66
25B50	-	-	-	-	-	-	900	80	242
30B30	-	-	-	600	10,5	21,5	900	24	72
30B46	-	-	-	545	29	54	810	65	172
30B50	-	-	-	-	-	-	1250	90	360
30B52	-	-	-	600	40	83	1000	89	304
30B70	-	-	-	940	68	212	1400	150	690
35B35	-	-	-	940	15	47	1400	33	152
35B40	-	-	-	1250	26	108	2000	60	380
35B50	-	-	-	1250	40	162	2000	90	570
35B63	-	-	-	1600	65	341	2400	152	1170
40B36	-	-	-	1010	16	56	1500	36	183
40B40	1250	15	61	2000	26	167	-	-	-
40B49	-	-	-	968	32	106	1440	70	335
40B50	-	-	-	2000	50	320	-	-	-
40B61A	-	-	-	2220	63	448	3300	140	1448
40B63	1345	24	107	2000	52	337	-	-	-
40B80	2260	49	355	3000	86	809	-	-	-
50B40	2300	12,5	94	3000	22	212	-	-	-
50B50	2110	10	70	2800	18	162	-	-	-
50B50D	-	-	-	1614	28	150	2400	61	480
50B50F	-	-	-	1735	33	192	2580	74	627
50B52A	2260	15	108	3000	26	247	-	-	-
50B63	-	-	-	3000	60	570	-	-	-
50B80	3800	50	623	5000	90	1442	-	-	-
60B63A	3800	36	443	5000	62	985	-	-	-
70B90	4400	24	338	-	-	-	-	-	-

* All sizes of B pumps are also available in BV version

The parameters are specified for clean water of density $\rho = 1000 \text{ kg/m}^3$ and temperature $T = 15^\circ\text{C}$.

HOT WATER PUMPS

WN

WN pumps are designed as stationary, horizontal multi-stage, ring-section pumps

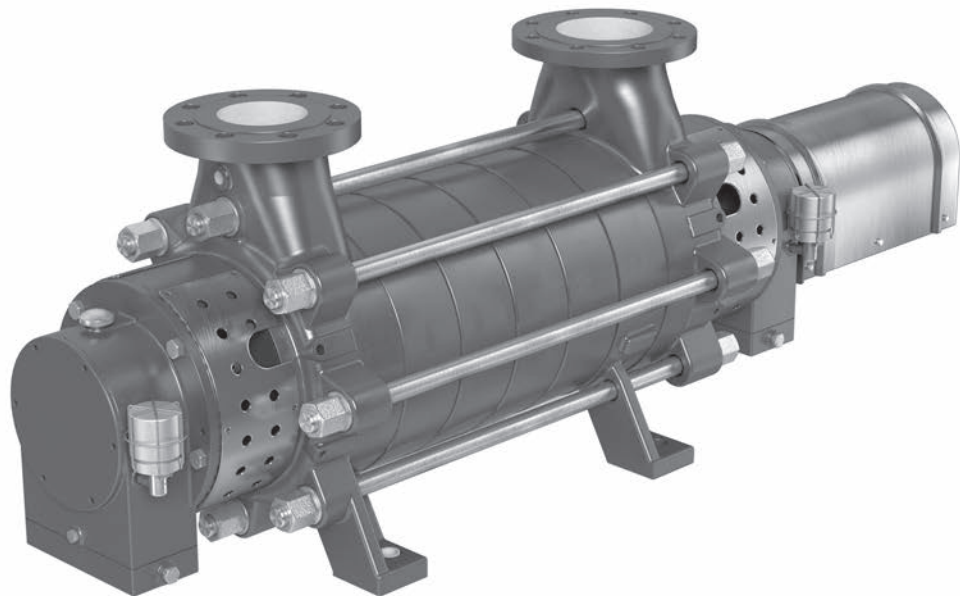

APPLICATION

The WN type pumps are designed to handle hot, clean and industrial water, of temperature up to 150°C. They can be applied in water supply systems, industrial cooling systems, and for the ability to pump hot water, in district heating and power plants.

DESIGN

The WN are horizontal, stationary, multistage, ring-section pumps. The delivery flange is directed vertically upward and the suction flange is directed horizontally or vertically depending on the size of pump. Closed impellers and vane diffusers are applied. The axial thrust is absorbed by a balance disk. The shaft seal can be sealed by a gland or mechanical seal.

MATERIALS OF CONSTRUCTION

The casings are made of cast iron. The impellers are made of cast steel or bronze. Special material versions can be selected for handling non-typical fluids.

CROSS-SECTION / LIST OF PUMP PARTS

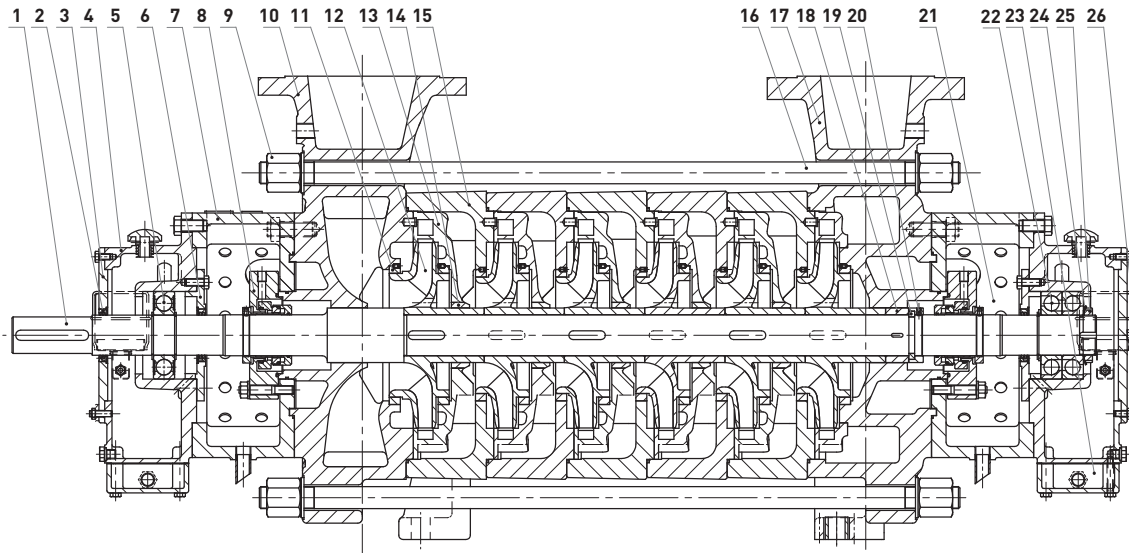

No.	Part name	No.	Part name
1	Shaft	14	Impeller Sealing ring
2	Labyrinth ring	15	Stage casing
3	Bearing housing cover	16	Tie bolt
4	Bearing housing	17	Discharge casing
5	Standard roller bearing	18	Spacer sleeve
6	Thrust bearing cover	19	Split ring
7	Bearing housing adapter	20	Retaining ring
8	Mechanical seal	21	Stuffing box guard
9	Tie bolt nut	22	Angular contact ball bearing
10	Suction casing	23	Cooling chamber cover
11	Impeller Sealing ring	24	Toothed washer
12	Impeller	25	Bearing nut
13	Vane diffuser	26	Oil level control

DIMENSIONS

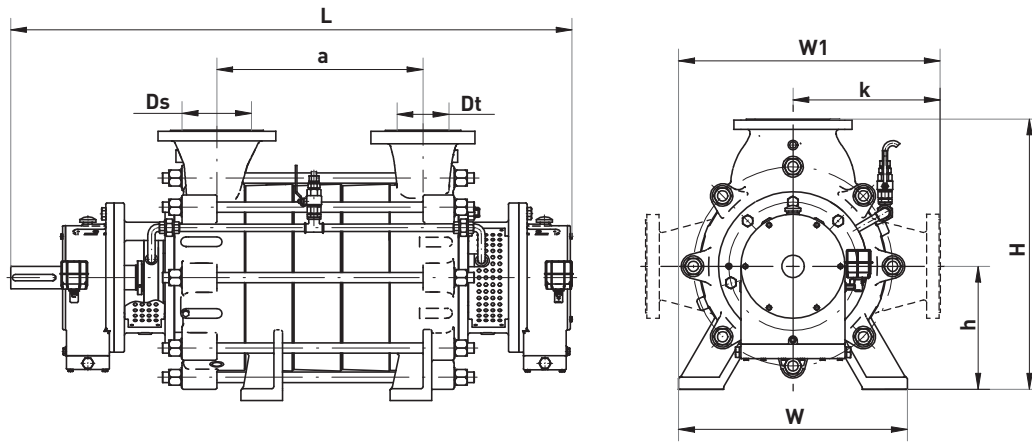

Pump type	Number of stages	Dimensions [mm]								
		L	a	W	W1	k	H	h	Ds	Dt
6WN18	2	760	155	320	385	225	425	200	80	65
	3	825	220	320	385	225				
	4	890	285	320	385	225				
	5	955	350	320	385	225				
	6	1020	415	320	385	225				
8WN20	2	848	175	400	480	280	505	225	100	80
	3	923	250	400	480	280				
	4	998	325	400	480	280				
	5	1073	400	400	480	280				
10WN22	2	946	205	400	515	315	565	250	125	100
	3	1036	295	400	515	315				
	4	1126	385	400	515	315				
	5	1216	475	400	515	315				
	6	1306	565	400	515	315				
	7	1396	655	400	515	315				
12WN25	2	1074	230	500	605	355	635	280	150	125
	3	1164	320	500	605	355				
	4	1254	410	500	605	355				
	5	1344	500	500	605	355				
	6	1434	590	500	605	355				
12WN32	2	1110	265	500	650	400	715	315	150	125
	3	1225	380	500	650	400				
	4	1340	495	500	650	400				
	5	1455	610	500	650	400				
	6	1570	725	500	650	400				
15WN36	2	1340	315	660	755	425	780	355	200	150
	3	1480	455	660	755	425				
	3	1620	595	660	755	425				
	5	1760	735	660	755	425				
	6	1900	875	660	755	425				
7	2040	1015	660	755	425					

RANGE OF OPERATION

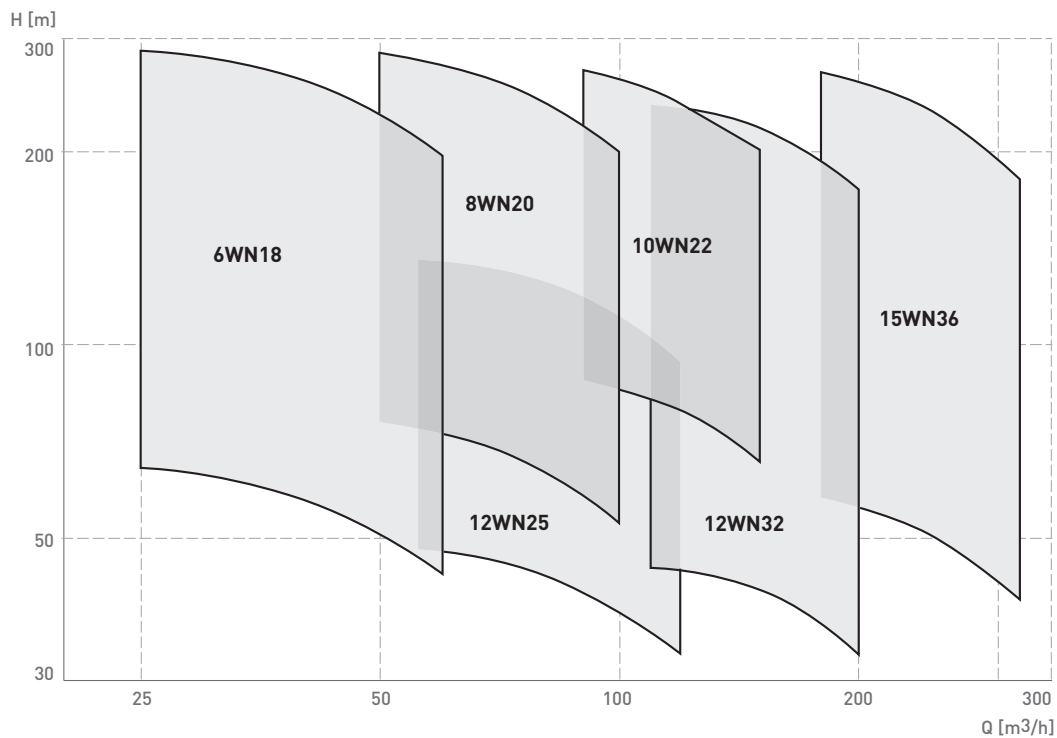

NOMINAL PARAMETERS

Pump type	Number of stages	Capacity Q [m³/h]	Head H [m]	Rotation speed n [rpm]	Motor rated power P _e [kW]	Weight m [kg]
6WN18	2	50	76	3000	18,5	138
	3		114	3000	30	157
	4		152	3000	37	176
	5		190	3000	45	195
	6		228	3000	55	214
8WN20	2	80	96	3000	30, 37	275
	3		144	3000	45, 55	302
	4		192	3000	75	329
	5		240	3000	75, 90	356
10WN22	2	120	120	3000	55, 75	283
	3		180	3000	75, 90, 110	320
	4		240	3000	90, 110, 132	357
	5		300	3000	110, 132, 160	394
	6		360	3000	132, 160, 200	431
	7		420	3000	160, 200, 250	468
12WN25	2	90	40	1500	15, 22	460
	3		60	1500	22, 30	514
	4		80	1500	22, 30, 37	568
	5		100	1500	30, 37, 45	622
	6		120	1500	37, 45, 55	676

Pump type	Number of stages	Capacity Q [m ³ /h]	Head H [m]	Rotation speed n [rpm]	Motor rated power P _s [kW]	Weight m [kg]
12WN32	2	170	60	1500	37, 55	568
	3		90	1500	55, 75	622
	4		120	1500	75, 90, 110	676
	5		150	1500	90, 110, 132	730
	6		180	1500	110, 132, 160	784
15WN36	2	250	80	1500	55, 75, 90	827
	3		120	1500	75, 90, 132	960
	4		160	1500	110, 132, 160	1093
	5		200	1500	132, 160, 200	1226
	6		240	1500	160, 200, 250	1359
	7		280	1500	200, 250, 315	1492

The parameters are specified for clean water of density $\rho = 1000 \text{ kg/m}^3$ and temperature $T = 15^\circ\text{C}$.

HOT WATER PUMPS

W

Horizontal, multistage,
ringsection centrifugal pumps
for hot water applications

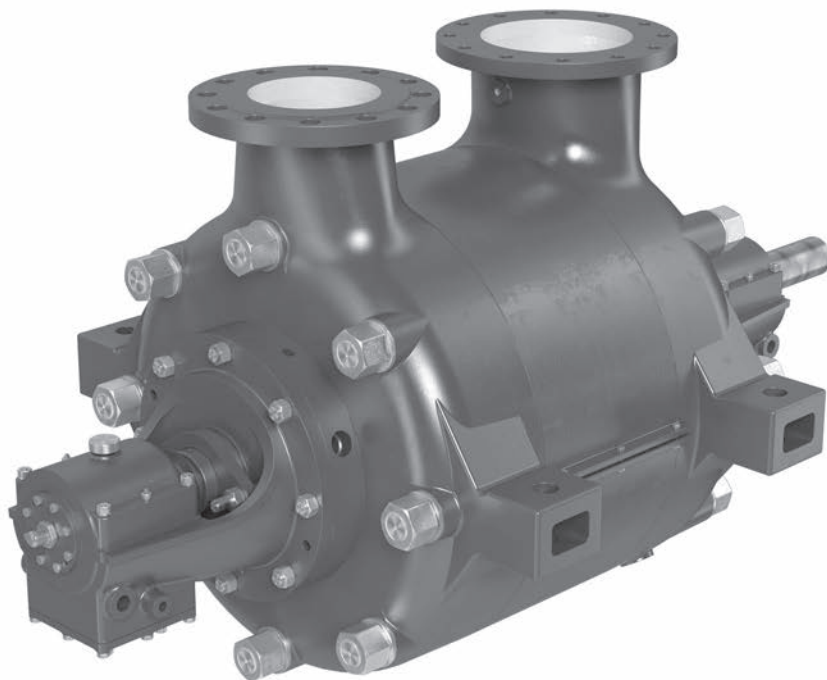

APPLICATION

The W pumps are designed to handle hot, clean and industrial water, of temperature up to 150°C. They can be applied in water supply systems, industrial cooling systems, and for the ability to pump hot water, in district heating and power plants.

DESIGN

The W pumps are horizontal, stationary, multistage, ring-section pumps. The delivery flange is directed vertically upward and the suction flange is directed horizontally or vertically depending on the size of pump. Closed impellers and vane diffusers are applied. The axial thrust is absorbed by a balance disk. The shaft seal can be sealed by a gland or mechanical seal.

MATERIALS OF CONSTRUCTION

The casings are made of cast iron. The impellers are made of cast steel or bronze. Special material versions can be selected for handling non-typical fluids.

CROSS-SECTION / LIST OF PUMP PARTS

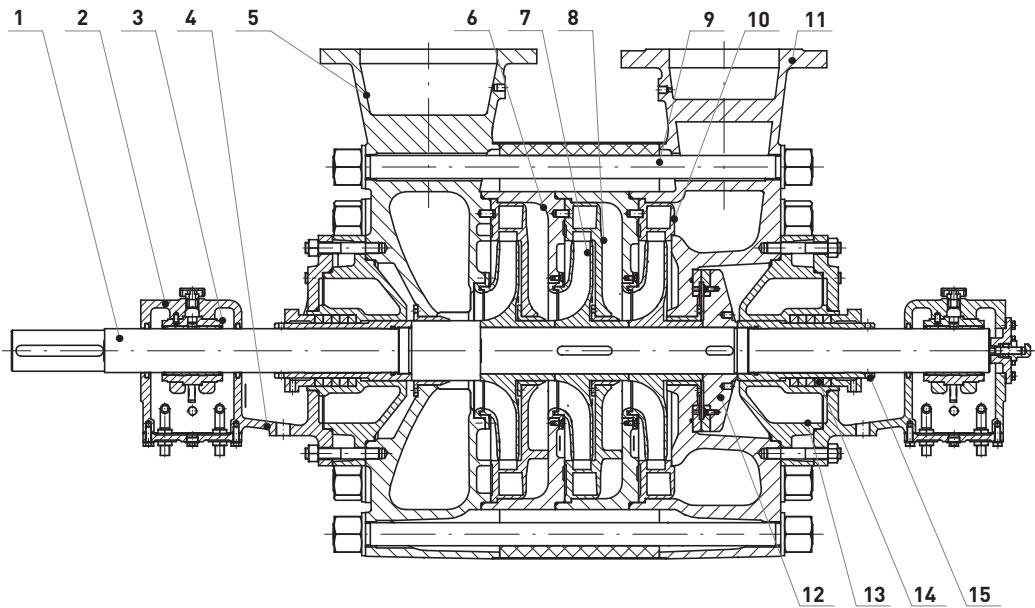

No.	Part name	No.	Part name	No.	Part name
1	Shaft	6	Stage casing	11	Discharge casing
2	Bearing housing cover	7	Impeller	12	Balance disk
3	Slide bearing	8	Diffuser	13	Stuffing box guard
4	Bearing casing	9	Tie bolt	14	Mechanical seal
5	Suction casing	10	Radial vane diffuser	15	Gland sleeve

DIMENSIONS

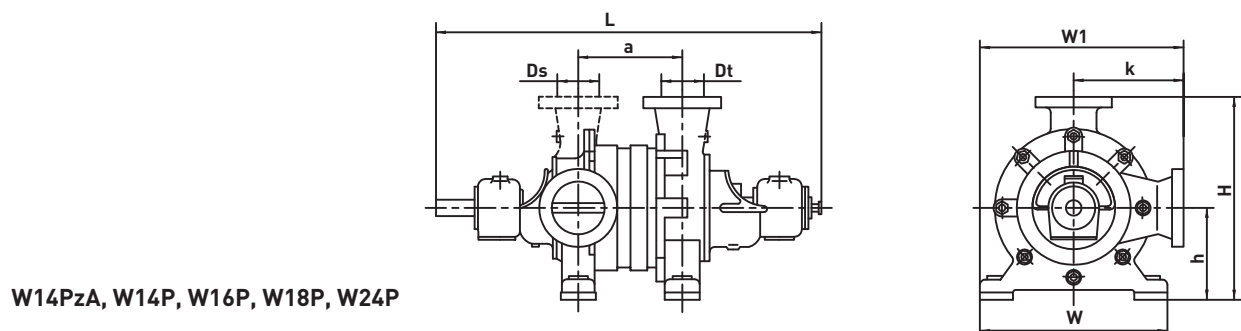
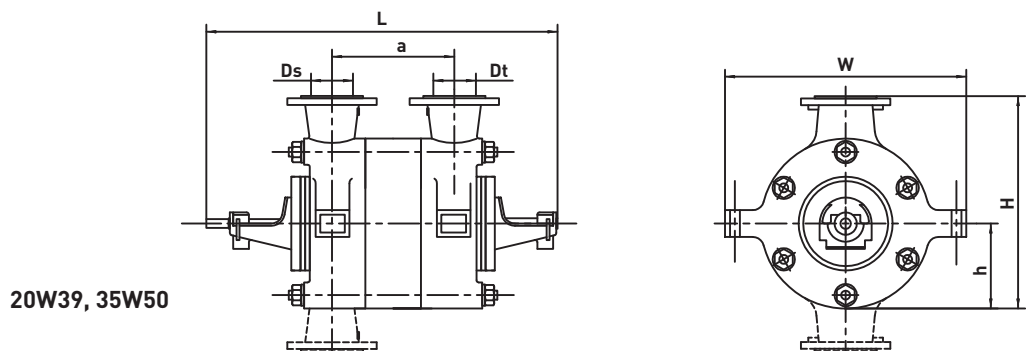

Pump type	Number of stages	Dimensions [mm]								
		L	a	W1	W	k	H	h	Ds	Dt
20W39	2	1723	405	-	1050	-	930	380	250	200
	3	1858	540							
	4	1993	675							
	5	2128	810							
	6	2263	945							
35W50	2	2455	660	-	1600	-	1425	575	400	350
	3	2690	895							
W14PzA	2	1340	250	695	650	370	650	280	125	100
	3	1430	340							
	4	1550	430							
	5	1640	520							
	6	1730	610							
	7	1820	700							
	8	1910	790							
W14PA	3	1477	370	695	650	370	650	280	150	125
	4	1587	480							
	5	1697	590							
	6	1807	700							
	7	1917	810							
	8	2027	920							
W14PB	3	1477	370	695	650	370	650	280	150	125
	4	1587	480							
	5	1697	590							
	6	1807	700							
	7	1917	810							
	8	2027	920							
W14PC	3	1477	370	695	650	370	650	280	150	125
	4	1587	480							
	5	1697	590							
	6	1807	700							
	7	1917	810							
	8	2027	920							
W16P	2	1446	320	810	720	450	780	330	200	150
	3	1576	450							
	4	1706	580							
	5	1836	710							
	6	1966	840							
W18P	2	1710	375	885	810	480	845	365	250	200
	3	1850	515							
	4	1990	655							
	5	2130	795							
	6	2270	935							
W24P	2	2283	580	1275	1150	700	1240	540	350	300
	3	2493	790							
	4	2703	1000							

RANGE OF OPERATION

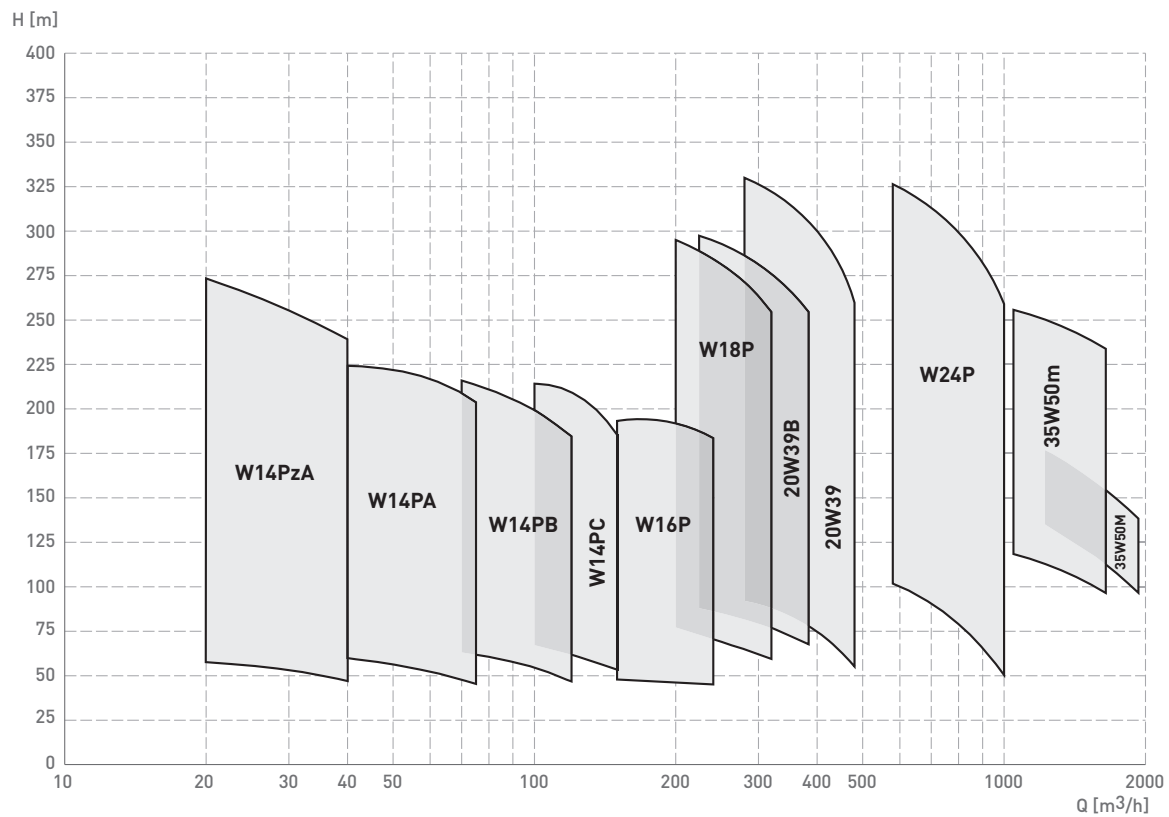

NOMINAL PARAMETERS

Pump type	Number of stages	Capacity Q [m³/h]	Head H [m]	Rotation Speed n [rpm]	Shaft power P [kW]	Weight m [kg]
W14PZA	2	30	69	1500	18,5	483
	3		104		30	545
	4		128		30	607
	5		160		37	670
	6		192		45	732
	7		224		45	794
	8		256		55	856
W14PA	3	60	81	1500	30	630
	4		108		37	735
	5		135		45	840
	6		162		55	945
	7		189		75	1050
	8		216		75	1155
	8		256		90	1320
W14PB	3	100	75	1500	30	630
	4		100		45	735
	5		125		55	840
	6		150		75	945
	7		175		75	1050
	8		200		90	1155
	8		256		110	1320

Pump type	Number of stages	Capacity Q [m ³ /h]	Head H [m]	Rotation Speed n [rpm]	Shaft power P [kW]	Weight m [kg]
W14PC	3	125	69	1500	45	630
	4		104		55	735
	5		130		75	840
	6		156		90	945
	7		161		110	1050
	8		208		132	1155
W16P	2	200	64	1500	55	830
	3		96		90	1000
	4		128		132	1170
	5		160		160	1340
	6		192		200	1510
W18P	2	250	94	1500	110	1245
	3		141		160	1475
	4		188		200	1705
	5		235		250	1940
	6		282		315	2170
20W39B	2	320	92	1500	132	1250
	3		138		200	1410
	4		184		250	1570
	5		230		315	1730
	6		276		355	1890
20W39	2	400	100	1500	160	1250
	3		150		250	1410
	4		200		315	1570
	5		250		400	1730
	6		300		500	1890
W24P	2	800	150	1500	400	3380
	3		225		800	3610
	4		300		1000	3850
35W50M	2	1500	160	1500	900	4560
	3		240		1250	5140
35W50M	2	1730	150	1500	1000	4560

The parameters are specified for clean water of density $\rho = 1000 \text{ kg/m}^3$ and temperature $T = 15^\circ\text{C}$.

HOT WATER PUMPS

A-P

A-P pumps are end suction, single stage horizontal, centrifugal pumps of upgraded semi-process design

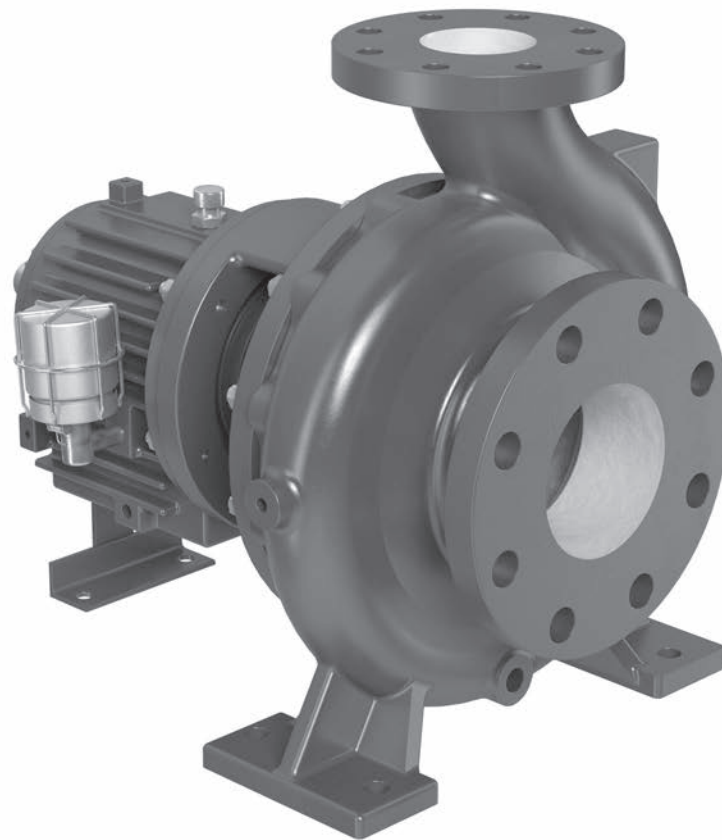

APPLICATION

The A-P pumps are designed to handle chemical products of high temperature and pressure. Due to the robust design, apart from the basic application in chemical plants, the A-P pumps can be applied in any industry where hot or toxic fluids under high pressure are to be pumped, such as, for example, power plants or district heating plants. Due to the compliance with Atex directive the A-P pumps can operate in areas where hazard of explosion is present.

DESIGN

Single stage, horizontal, end suction pumps with own bearings classified as UMDP (upgraded medium duty pumps). The design is also in compliance with Atex directive. The A-P pumps are equipped with large seal chamber providing space to install any required mechanical seal configuration. If necessary the pumps can be equipped with heating or cooling jackets or with inducers to improve the suction properties. The design of the pumps of different sizes is unified – there are five standard bearings assemblies and seal chambers which can be combined with different wet ends. Such a unification reduces the quantity of spare parts to be stored and eases the maintenance.

MATERIALS OF CONSTRUCTION

A-P pumps are available in different material versions including stainless steel, stainless cast steel, duplex, superduplex and hastalloy. The materials of construction are selected individually for each application.

CROSS-SECTION / LIST OF PUMP PARTS

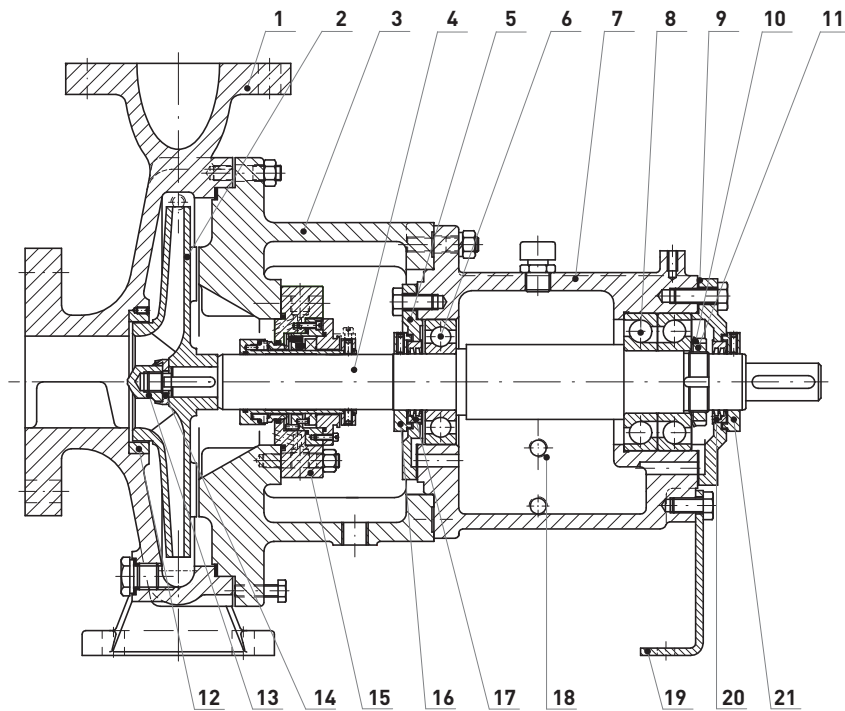

No.	Part name	No.	Part name
1	Pump casing	12	Casing Sealing ring
2	Impeller	13	Impeller nut
3	Seal casing	14	Impeller washer
4	Shaft	15	Mechanical seal
5	Radial Thrust bearing cover	16	Expeller
6	Radial bearing	17	Labyrinth
7	Bearing housing	18	Oil filler
8	Thrust bearing	19	Casing support
9	Thrust Thrust bearing cover	20	Labyrinth
10	Toothed washer	21	Expeller
11	Bearing nut KM		

DIMENSIONS

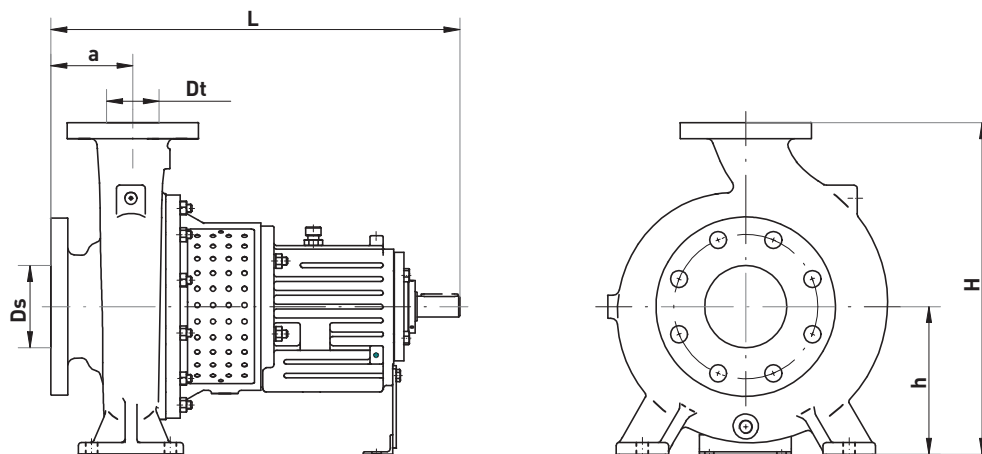

Pump type	Dimensions [mm]					
	D_s	D_t	L	a	H	h
3A16-P	50	32	465	80	292	132
3A20-P			465	80	340	160
3A25-P			600	100	405	180
4A20-P	65	40	485	100	340	160
4A25-P			600	100	405	180
4A32-P			625	125	450	200
5A16-P	65	50	465	80	292	132
5A20-P			485	100	360	160
5A25-P			625	125	405	180
5A32-P	80	50	625	125	505	225
6A16-P			485	100	340	160
6A20-P			600	100	405	180
6A25-P	100	65	625	125	450	200
6A32-P			655	125	505	225
8A16-P			100	80	600	100
8A20-P	125	80	625	125	430	180
8A25-P			625	125	505	225
8A32-P			655	125	565	250
10A20-P	125	100	625	125	480	200
10A25-P			670	140	505	225
10A32-P			670	140	565	250
12A25-P	150	125	670	140	605	250
12A32-P			670	140	635	280
15A25-P			690	160	655	280
15A32-P	200	150	830	160	715	315
15A40-P			830	160	765	315
20A25-P			200	200	850	180
20A32-P	250	200	870	200	805	355
20A40-P			870	200	855	355
20A50-P			900	200	990	425
25A40-P	300	250	900	200	1025	425
25A50-P	250	250	900	200	1145	475
30A40-P	350	300	950	250	1105	475

RANGE OF OPERATION

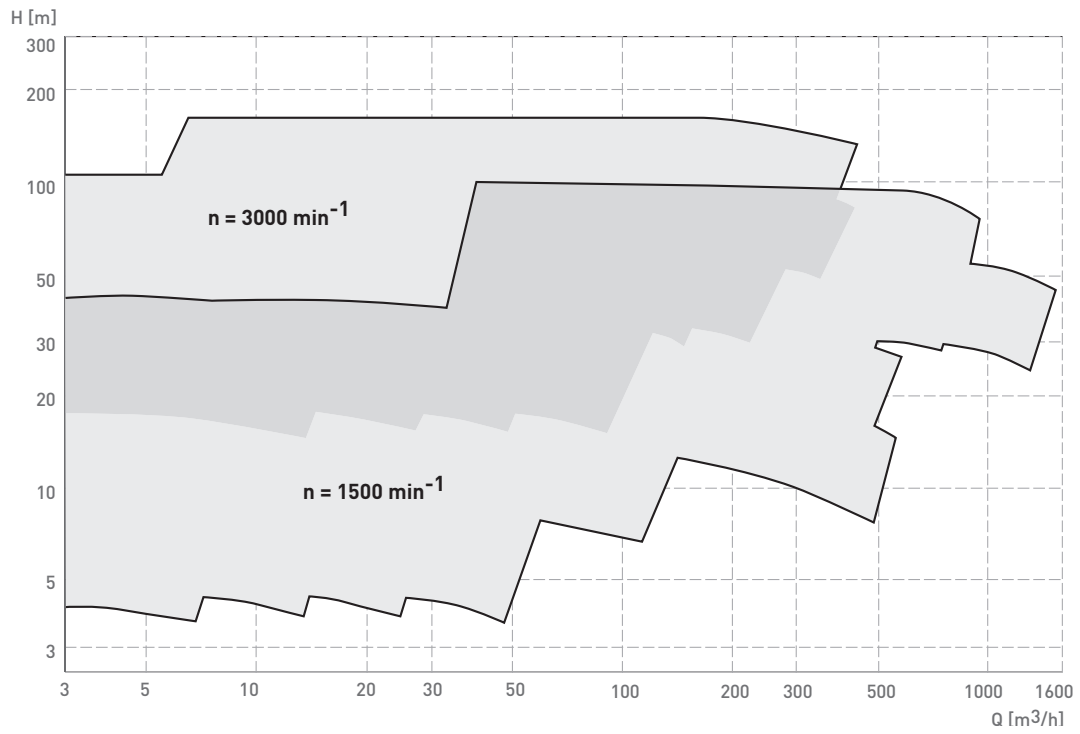

NOMINAL PARAMETERS

Pump type	Rotation speed n=3000 [rpm]			Rotation speed n=1500 [rpm]			Weight m [kg]
	Capacity Q [m³/h]	Head H [m]	Shaft power P [kW]	Capacity Q [m³/h]	Head H [m]	Shaft power P [kW]	
3A16-P	12,5	32	2	6,3	8	0,3	65
3A20-P	12,5	50	3,8	6,3	12,5	0,6	75
3A25-P	12,5	80	7,8	6,3	20	1,1	120
4A20-P	25	50	5,7	12,5	12,5	0,8	80
4A25-P	25	80	11,6	12,5	20	1,6	122
4A32-P	25	128	23,6	12,5	32	3,4	153
5A16-P	25	32	3,8	12,5	8	0,5	70
5A20-P	50	50	9,2	25	12,5	1,3	82
5A25-P	50	80	19,1	25	20	2,4	124
5A32-P	50	128	33,5	25	32	4,5	158
6A16-P	50	32	6,0	25	8	0,8	73
6A20-P	100	50	17,7	50	12,5	2,4	110
6A25-P	100	80	32,5	50	20	4,4	138
6A32-P	100	128	53,7	50	32	7,3	190
8A16-P	100	32	11,7	50	8	1,7	98
8A20-P	160	50	27,2	80	12,5	3,7	119
8A25-P	160	80	45,9	80	20	5,8	142
8A32-P	160	128	79,7	80	32	10,6	196
10A20-P	250	50	42,6	125	12,5	5,5	138
10A25-P	250	80	69,9	125	20	8,7	204
10A32-P	250	128	118,6	125	32	15,1	212
12A25-P	400	80	111,8	200	20	13,1	218
12A32-P	400	128	176,6	200	32	22,6	230
15A25-P	-	-	-	315	20	21,5	268
15A32-P	-	-	-	315	32	33,5	310
15A40-P	-	-	-	315	50	51,7	385
20A25-P	-	-	-	500	20	34,5	342
20A32-P	-	-	-	500	32	52,5	392
20A40-P	-	-	-	500	50	82,1	422
20A50-P	-	-	-	500	80	145,3	450
25A40-P	-	-	-	800	50	129,8	465
25A50-P	-	-	-	800	80	235,7	495
30A40-P	-	-	-	1250	50	212,9	580

The parameters are specified for clean water of density $\rho = 1000 \text{ kg/m}^3$ and temperature $T = 15^\circ\text{C}$.

HOT WATER PUMPS

A-P10

A-P10 pumps are end suction, single stage, horizontal process pumps compliant with 10th edition of API 610 standard



APPLICATION

The A-P10 pumps are designed to handle petrochemical and chemical products of high temperature and pressure. Due to the robust design, apart from the basic application in petrochemical and chemical plants the A-P10 pumps can be applied in any industry where hot or toxic fluids under high pressure are to be pumped, such as, for example, power plants or district heating plants. Due to the compliance with Atex directive the A-P10 pumps can operate in areas where hazard of explosion is present.

DESIGN

Single stage, horizontal, end suction pumps with own bearings designed according to API 610 standard 10th edition – OH2 type. All the dimensions and design features are compliant with the standard. The design is also in compliance with Atex directive. The A-P10 pumps are equipped with large seal chamber providing space to install any required mechanical seal configuration (API plan). If necessary the pumps can be equipped with heating or cooling jackets or with inducers to improve the suction properties. The design of the pumps of different sizes is unified – there are four standard bearings assemblies and seal chambers which can be combined with different wet ends. Such a unification reduces the quantity of spare parts to be stored and eases the maintenance.

MATERIALS OF CONSTRUCTION

A-P10 pumps are available in material classes according to API 610 standard, including stainless steel, stainless cast steel, duplex, superduplex and hastalloy. The materials of construction are selected individually for each application according to the recommendations included in the API 610 standard and following the client's suggestions.

CROSS-SECTION / LIST OF PUMP PARTS

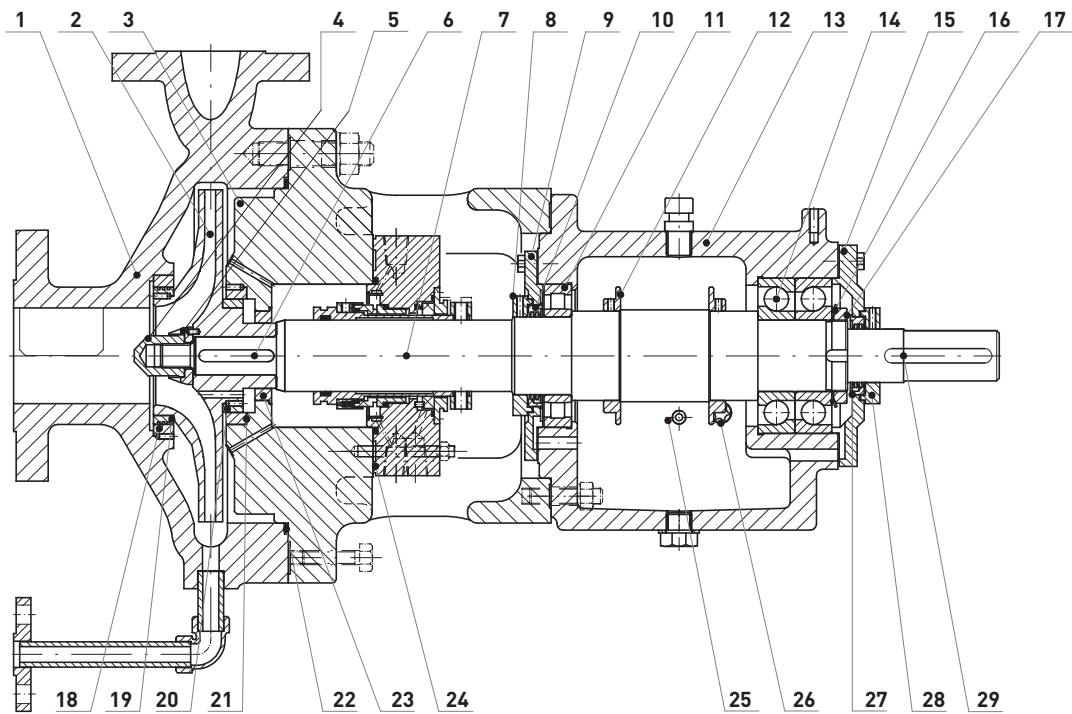

No.	Part name	No.	Part name
1	Pump casing	16	Toothed washer
2	Impeller	17	KM bearing nut
3	Casing cover	18	Casing sealing ring
4	Impeller nut	19	Impeller sealing ring
5	Impeller washer	20	Impeller sealing ring
6	Parallel key	21	Gland sealing ring
7	Shaft	22	Spiral gasket
8	Deflector	23	Stuffing box insert
9	Radial Thrust bearing cover	24	Mechanical seal
10	Labyrinth	25	Constant level oil
11	Radial bearing	26	Oil level indicator
12	Expeller ring	27	Labyrinth
13	Bearing housing	28	Expeller
14	Thrust bearing	29	Parallel key
15	Thrust Thrust bearing cover		

DIMENSIONS

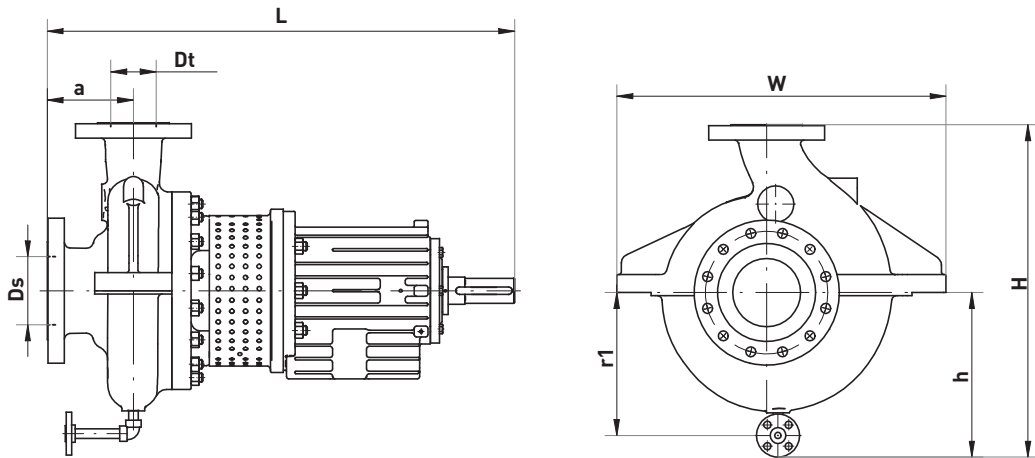

Pump type	Dimensions [mm]							
	D_s	D_t	L	a	W	H	h	r_1
3A16-P10	50	40	710	130	365	440	225	195
3A20-P10			725	145	430	490	275	220
3A25-P10			805	145	520	560	305	250
4A16-P10	80	40	710	130	430	440	255	195
4A20-P10			725	145	430	490	275	220
4A25-P10			805	145	520	560	305	250
4A32-P10			805	145	580	612	327	275
5A16-P10	80	50	710	130	430	470	270	210
5A20-P10			725	145	430	500	275	220
5A25-P10			825	165	520	560	305	250
5A32-P10			825	165	580	622	337	280
5A38-P10			825	165	680	715	375	320
6A16-P10	100	80	725	145	470	522	287	230
6A20-P10			825	165	520	560	305	245
6A25-P10			825	165	580	620	335	275
6A32-P10			1030	190	660	665	340	285
6A38-P10			1050	210	740	760	375	320
10A20-P10	150	100	825	165	580	630	330	270
10A25-P10			1030	190	660	710	360	305
10A32-P10			1030	190	395-330	745	375	320
10A38-P10			1050	210	405-355	835	415	360
12A25-P10	200	150	1050	210	395-330	775	380	325
12A32-P10			1050	210	395-330	830	410	355
12A38-P10			1050	210	425-375	920	460	405
20A45-P10	250	200	1090	250	515-430	1080	530	470

RANGE OF OPERATION

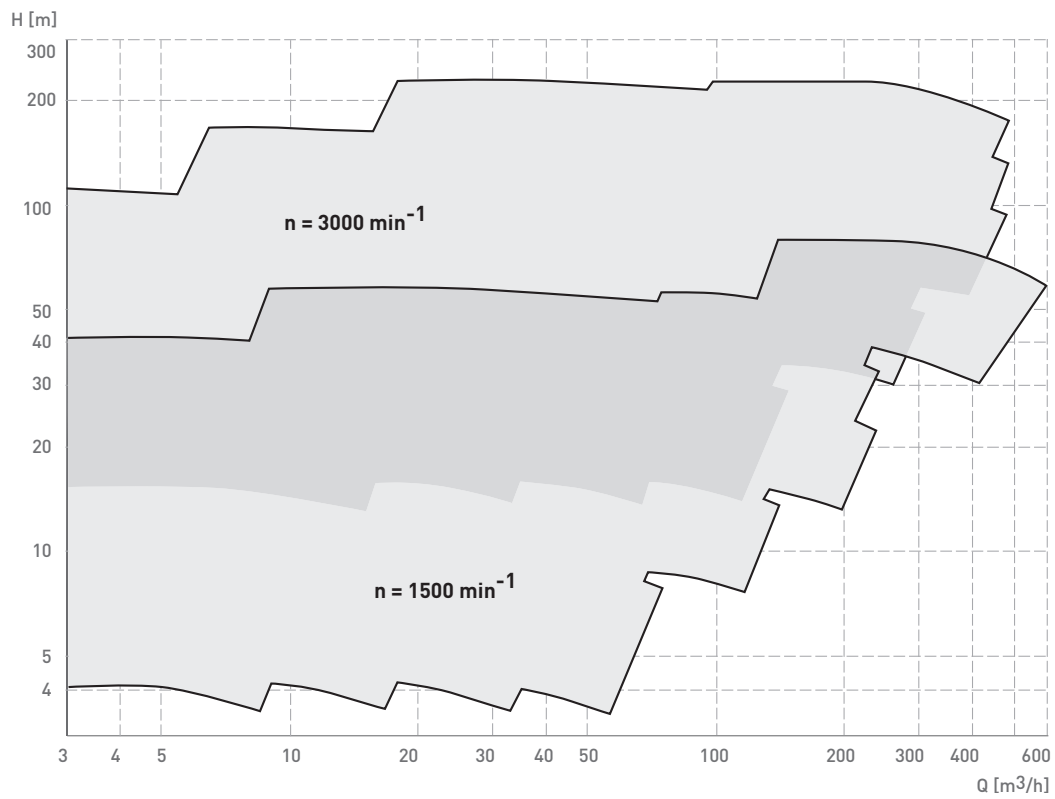

NOMINAL PARAMETERS

Pump type	Rotation speed n=3000 [rpm]			Rotation speed n=1500 [rpm]			Weight m [kg]
	Capacity Q [m ³ /h]	Head H [m]	Shaft power P [kW]	Capacity Q [m ³ /h]	Head H [m]	Shaft power P [kW]	
3A16-P10	12,5	32	2,3	6,3	8	0,3	129
3A20-P10	12,5	50	4,4	6,3	12,5	0,6	154
3A25-P10	12,5	80	10,1	6,3	20	1,5	230
4A16-P10	25	32	3,6	12,5	8	0,5	125
4A20-P10	25	50	6,2	12,5	12,5	0,9	140
4A25-P10	25	80	24,8	12,5	20	0,4	232
4A32-P10	25	128	22,6	12,5	32	2,7	267
5A16-P10	50	32	6,2	25	8	0,9	136
5A20-P10	50	50	9,2	25	12,5	1,2	161
5A25-P10	50	80	17,3	25	20	2,4	240
5A32-P10	50	128	33,5	25	32	4,4	276
5A38-P10	50	200	56,8	25	50	7,7	354
6A16-P10	100	32	11,5	50	8	1,5	164
6A20-P10	100	50	17,7	50	12,5	2,3	239
6A25-P10	100	80	30,7	50	20	3,9	237
6A32-P10	100	128	56,3	50	32	7,3	416
6A38-P10	100	200	94	50	50	12,2	543
10A20-P10	250	50	43,7	125	12,5	5,5	233
10A25-P10	250	80	66,5	125	20	8,5	416
10A32-P10	250	128	122,8	125	32	15,6	425
10A38-P10	250	200	189,2	125	50	24,0	559
12A25-P10	400	80	110,4	200	20	14,0	469
12A32-P10	400	128	178,9	200	32	22,9	506
12A38-P10	400	200	307,0	315	50	62,2	621
20A45-P10	-	-	-	500	70	117,7	775

The parameters are specified for clean water of density $\rho = 1000 \text{ kg/m}^3$ and temperature $T = 15^\circ\text{C}$.

STATIONARY PUMPS

A

A pumps are general purpose end suction, single stage, horizontal centrifugal pumps

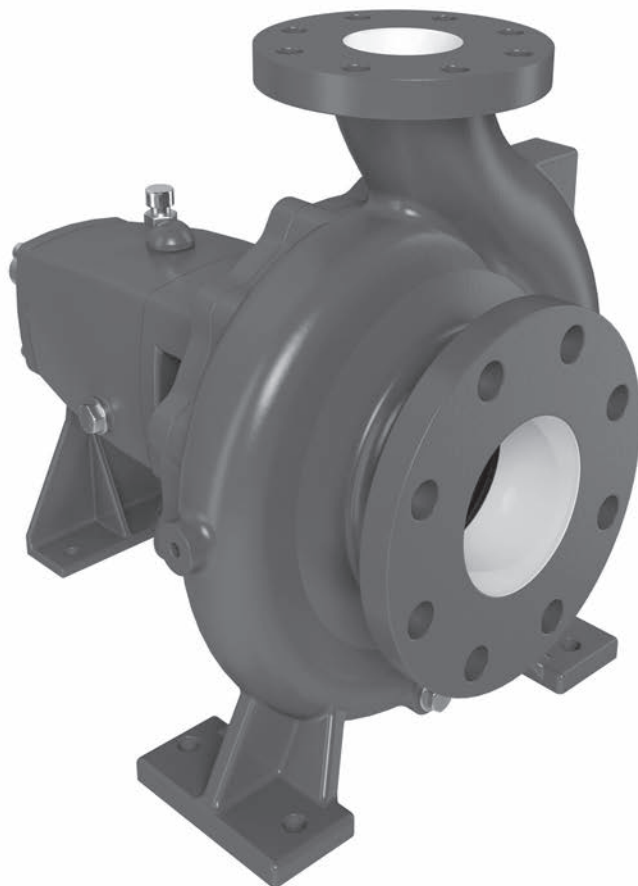

APPLICATION

The A pumps are universal, general purpose pumps designed to handle different fluids such as clean, cold water, hot water, contaminated water and some chemicals. They are applicable in many industries including, for example, water supply, power industry, steel works etc.

DESIGN

Single stage, horizontal, end suction pumps with own bearings, closed impellers and spiral casings. The pumps are of back-pull out design, so they can be disassembled without disconnecting from the pipelines after removing the distant coupling. Mechanical seals of different types can be applied depending on the fluid pumped. The bearings are roller type, oil lubricated.

MATERIALS OF CONSTRUCTION

A pumps are available in different material versions including cast iron, cast steel and stainless cast steel. The materials of construction are selected individually for each application according to the kind of fluid.

CROSS-SECTION / LIST OF PUMP PARTS

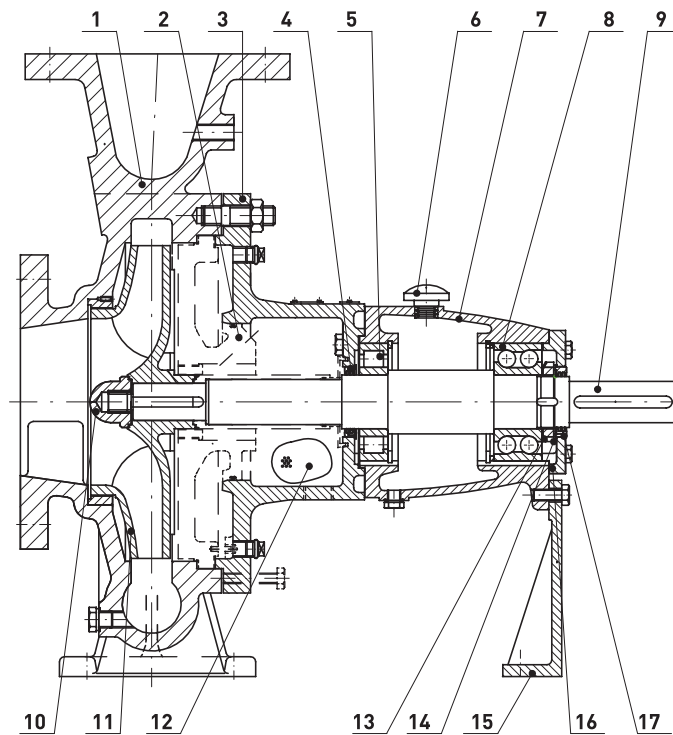

No.	Part name	No.	Part name
1	Casing	10	Impeller nut
2	Stuffing box	11	Impeller
3	Bearing housing adapter	12	Stuffing box guard
4	Labyrinth seal	13	Toothed washer
5	Bearing	14	Bearing nut
6	Vent plug	15	Support
7	Bearing housing	16	Thrust bearing cover
8	Bearing	17	Labyrinth seal
9	Shaft		

DIMENSIONS

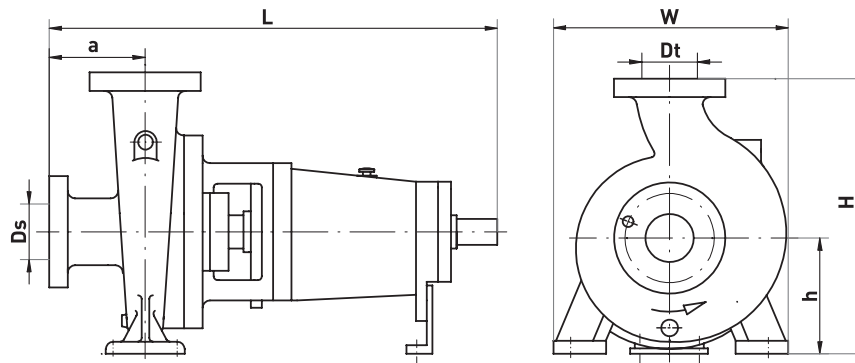

Pump type	Dimension [mm]						
	L	a	W	H	h	Ds	Dt
3A13	465	80	190	252	112	50	32
3A16	465	80	240	292	132	50	32
3A20	465	80	240	340	160	50	32
5A13	465	80	210	252	112	65	50
5A16	465	80	240	292	132	65	50
5A20A	485	100	265	360	160	80	50
5A25	625	125	320	405	180	80	50
6A16	485	100	265	340	160	80	65
6A20	600	100	320	405	180	100	65
6A25A	625	125	360	450	200	100	65
8A16	600	100	280	360	160	100	80
8A20	625	125	345	430	180	125	80
8A25A	625	125	400	505	225	125	80
10A20	625	125	360	480	200	125	100
10A25A	670	140	400	505	225	125	100
12A25	670	140	400	605	250	150	125
12A32A	670	140	500	635	280	150	125
15A25	690	160	500	655	280	200	150
15A32A	830	160	550	715	315	200	150
15A40	830	160	550	765	315	200	150
20A25	850	180	550	780	355	200	200
20A32	870	200	550	805	355	250	200
20A40	870	200	550	855	355	250	200
20A50A	970	200	660	985	425	250	200
25A32	920	250	660	960	400	300	250
25A40	970	200	800	1025	425	300	250
25A50	970	200	800	1145	475	250	250
30A40	1020	250	800	1105	475	350	300

RANGE OF OPERATION

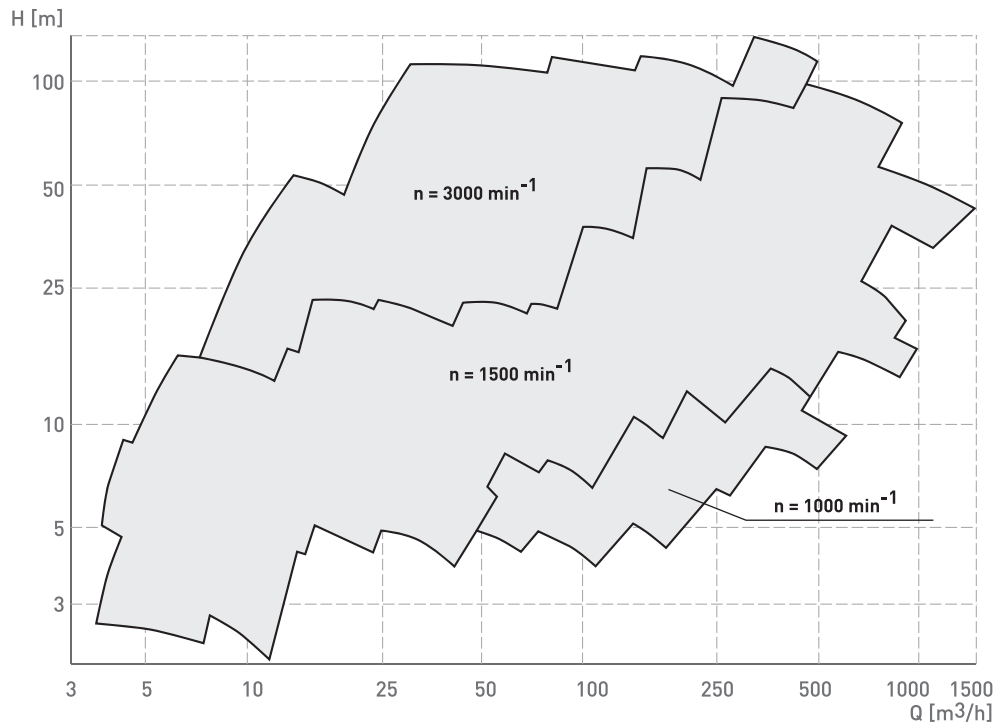

NOMINAL PARAMETERS

Pump type	Rotation speed $n=1450$ [rpm]			Rotation speed $n=2900$ [rpm]			Weight m [kg]
	Capacity Q [m ³ /h]	Head H [m]	Shaft power P [kW]	Capacity Q [m ³ /h]	Head H [m]	Shaft power P [kW]	
3A13	6,3	5	0,75	12,5	20	3	47
3A16		8	1,5	12,5	32	5,5	45
3A20		12,5	3,0	12,5	50	7,5	55
5A13	12,5	5	2,2	25	20	7,5	49
5A16	12,5	8	3,0	25	32	15	56
5A20A	25	12,5	5,5	50	50	22	66
5A25	25	20	11	50	80	45	96
6A16	25	8	4	50	32	18,5	72
6A20	50	12,5	7,5	100	50	45	81
6A25A	50	20	15	100	80	75	114
8A16	50	8	4	100	32	30	80
8A20	80	12,5	11	160	50	55	103
8A25A	80	20	18,5	160	80	90	130

Pump type	Rotation speed n=1450 [rpm]			Rotation speed n=2900 [rpm]			Weight m [kg]
	Capacity Q [m ³ /h]	Head H [m]	Shaft power P [kW]	Capacity Q [m ³ /h]	Head H [m]	Shaft power P [kW]	
10A20	125	12,5	15	250	50	90	100
10A25A		20	30		80	132	148
12A25	200	20	37	400	80	200	152
12A32A		32	55		128	250	175
15A25	315	20	45	-	-	-	180
15A32A		32	75	-	-	-	292
15A40		50	90	-	-	-	322
20A25	500	16	55	-	-	-	256
20A32		32	110	-	-	-	335
20A40		50	160	-	-	-	380
20A50A		80	250	-	-	-	480
25A32	800	32	132	-	-	-	350
25A40		50	250	-	-	-	458
25A50		80	355	-	-	-	524
30A40	1250	50	315	-	-	-	560

The parameters are specified for clean water of density $\rho = 1000 \text{ kg/m}^3$ and temperature $T = 15^\circ\text{C}$.

STATIONARY PUMPS

FY

FY are single stage, end suction horizontal centrifugal pumps for contaminated and viscous fluids

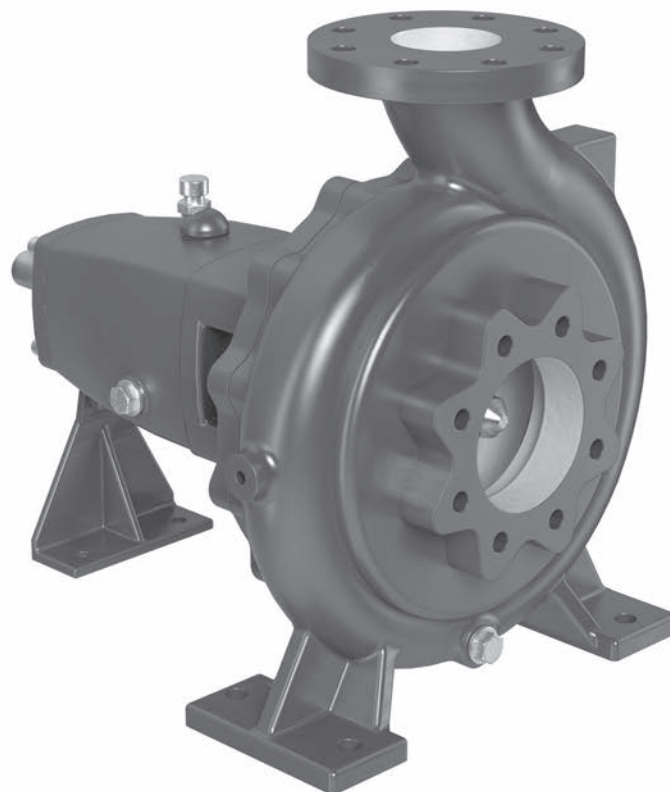

APPLICATION

The FY type pumps are designed to handle fluids of higher density and viscosity, such as contaminated water, sewage, juices, lime slurries etc. The typical applications include sugar factories, waste water treatment plants, FDG installations in power plants etc.

DESIGN

Single stage, horizontal, end suction pumps with own bearings and spiral casings. Semi-open impellers are applied in order to reduce the danger of blocking by solid particles. The casing is protected by a liners made of wear resistant alloy. The pumps are of back-pull out design, so they can be disassembled without disconnecting from the pipelines after removing the distant coupling. Gland seals or mechanical seals of different types can be applied depending on the fluid pumped. The bearings are roller type, oil lubricated.

MATERIALS OF CONSTRUCTION

F-Y pumps are available in different material versions selected individually for each application according to the kind of fluid. In standard version the wet end elements are made of wear resistant chromium cast steel.

CROSS-SECTION / LIST OF PUMP PARTS

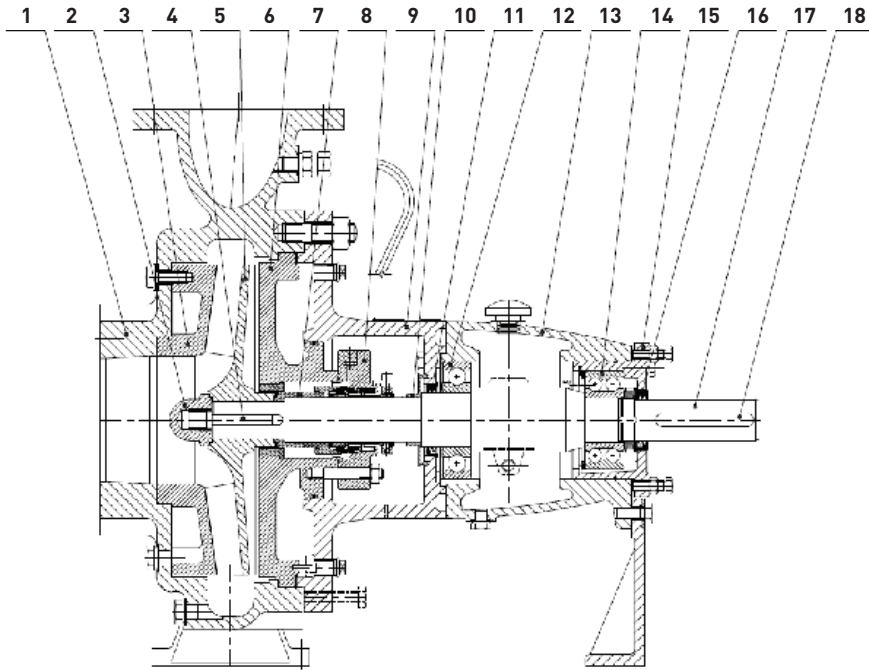

No.	Part name	No.	Part name	No.	Part name
1	Casing	7	Shaft seal	13	Bearing housing
2	Nut	8	Mechanical seal	14	Bearing
3	Front liner	9	Joining piece	15	Insert
4	Key	10	Expeller	16	Labyrinth
5	Impeller	11	Labyrinth	17	Shaft
6	Rear liner	12	Bearing	18	Key groove

DIMENSIONS

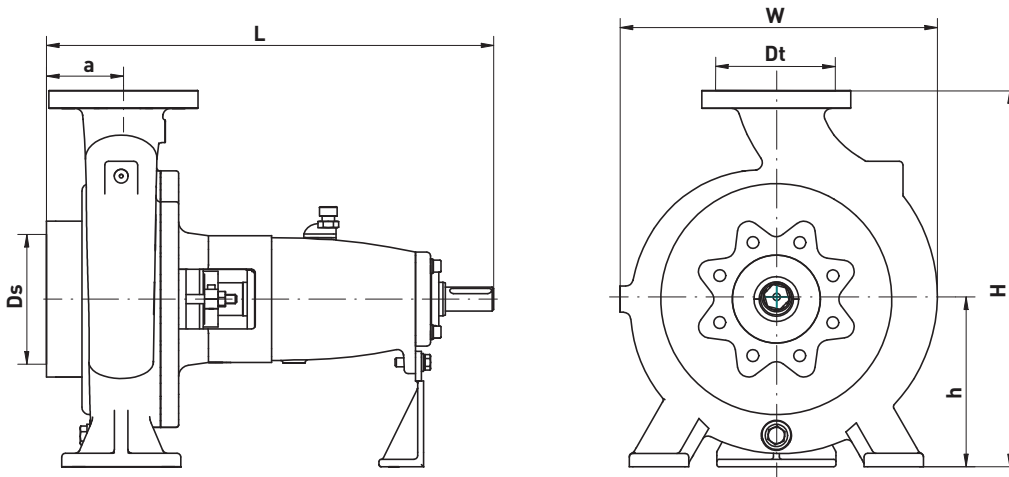

Pump type	Dimension [mm]						
	L	a	W	H	h	Ds	Dt
5FY32	655	125	403	505	225	80	50
6FY32	655	125	403	505	225	100	65
6FY40	655	125	488	635	280	100	65
10FY32	670	140	425	565	250	125	100
10FY40	610	140	501	635	280	125	100
12FY40	810	140	555	715	315	150	125
12FY50	830	160	683	875	375	150	125
15FY50	950	180	697	875	375	200	150

RANGE OF OPERATION

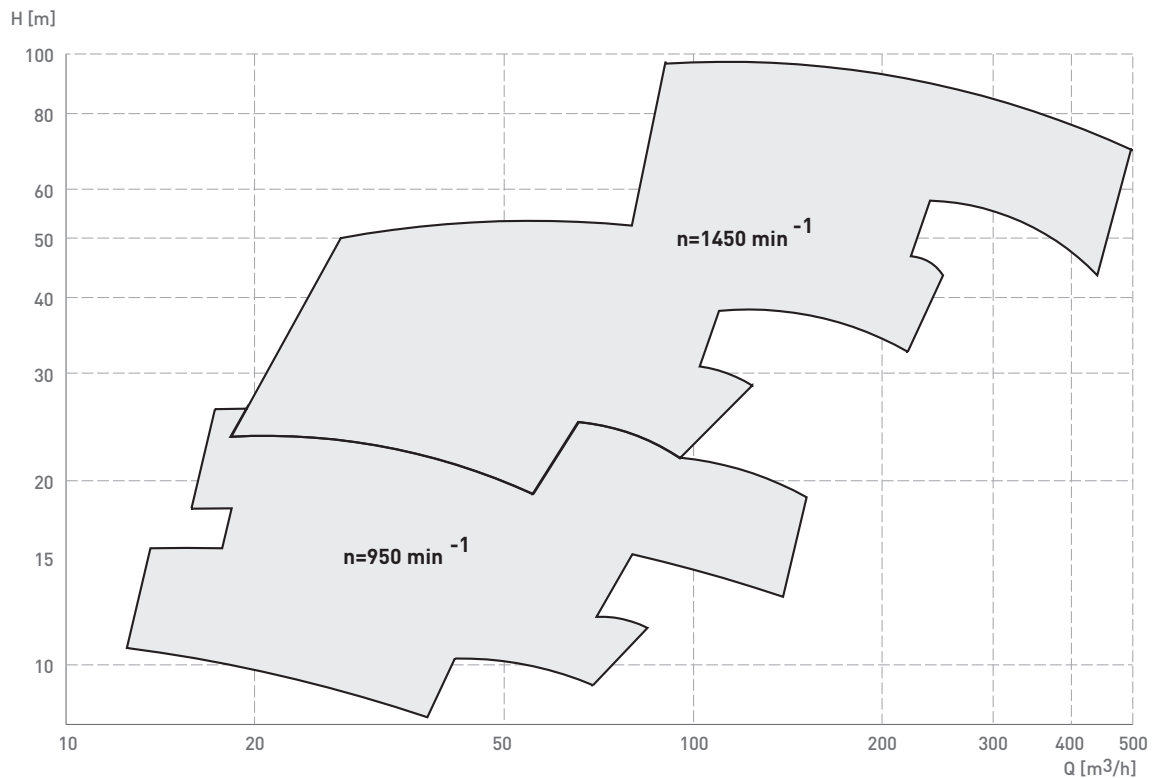

NOMINAL PARAMETERS

Pump type	Rotation speed n=950 [rpm]			Rotation speed n=1450 [rpm]			Weight m [kg]
	Capacity Q [m³/h]	Head H [m]	Motor rated power P _s [kW]	Capacity Q [m³/h]	Head H [m]	Motor rated power P _s [kW]	
5FY32	13	14	11	20	32	22	160
6FY32	33	14	15	50	32	30	170
6FY40	33	21	18,5	50	50	37	210
10FY32	66	14	11	100	32	37	180
10FY40	66	21	18,5	100	50	55	230
12FY40	131	21	30	200	50	90	280
12FY50	131	34	45	200	80	132	370
15FY50	262	34	75	400	80	200	430

The parameters are specified for clean water of density $\rho = 1000 \text{ kg/m}^3$ and temperature $T = 15^\circ\text{C}$.

STATIONARY SLURRY PUMPS

MF

MF are rubber-lined single stage,
horizontal slurry pumps
for abrasive solids

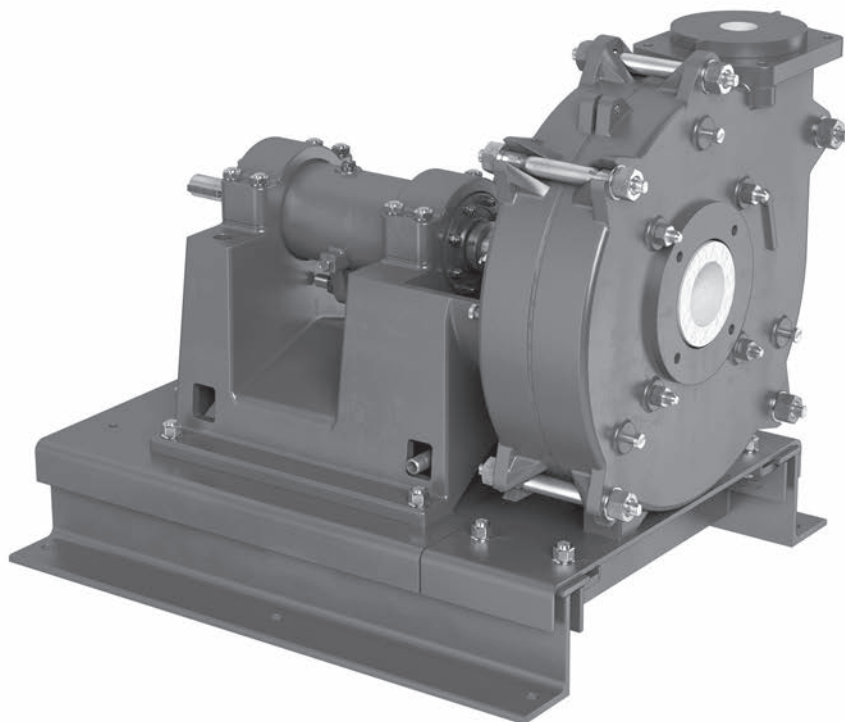

APPLICATION

MF pumps are designed to handle slurries containing high concentration of fine solids.

Typical application include:

- Copper ore processing plants
- Hydraulic transport of sand
- FGD installations in power plants

DESIGN

Stationary, horizontal, single-stage rubber lined slurry pumps with rubber impellers and spiral casing. The entire rotating assembly can be shifted in axial direction in order to adjust the sealing gap between the impeller and the front liner. The axial thrust is absorbed by roller bearings. The suction flange is situated horizontally at the pump axis. The delivery flange can be directed vertically upwards, horizontally or at an angle of 45°. The pumps are powered by motor by v-belt transmission. The pumps are equipped with a special frame allowing for moving the bearing casing and one half of the pump casing which enables rubber liners and impeller replacement without disconnecting the pump flanges from the pipelines. A stuffing box with gland water led to the lantern ring is applied as a standard for shaft sealing. Version with mechanical seal is also applicable.

MF pumps can be made in a vertical version.

MATERIALS OF CONSTRUCTION

Impeller and liners – rubber
Pump casing and bearing casing – cast iron
Shaft – alloy steel

CROSS-SECTION / LIST OF PUMP PARTS

No.	Part name
1	Pump base frame
2	Pump casing
3	Bearing assembly
4	Stuffing box casing
5	Casing 2
6	Casing liner
7	Impeller
8	Casing liner
9	Casing 1
10	Suction liner

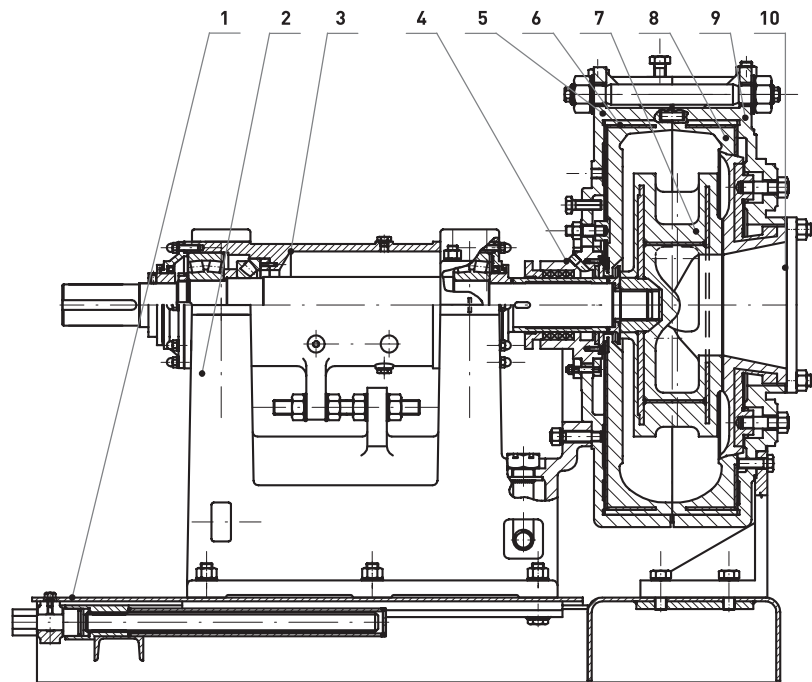

DIMENSIONS

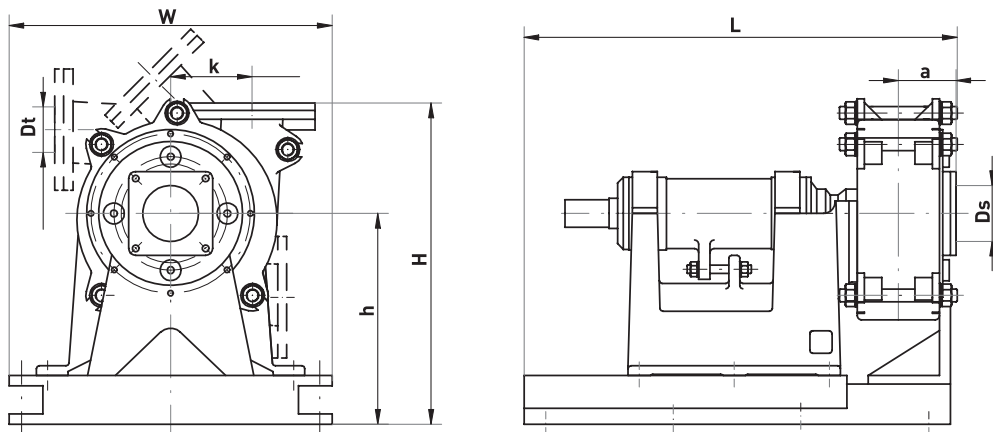

Dimension [mm]	Pump type						
	MF 65x50	MF 100x75	MF 200x150	MF 250x200	MF 300x250	MF 350x300	MF400x350
L	864	864	1525	1525	1855	1855	1855
a	111	111	206	247	270	307	323
W	764	764	1156	1156	1330	1330	1330
k	225	200	293	381	457	515	578
H	740	720	1186	1242	1624	1664	1778
h	455	455	774	774	1028	1028	1108
Ds	65	100	200	250	300	350	400
Dt	50	75	150	200	250	300	350

RANGE OF OPERATION

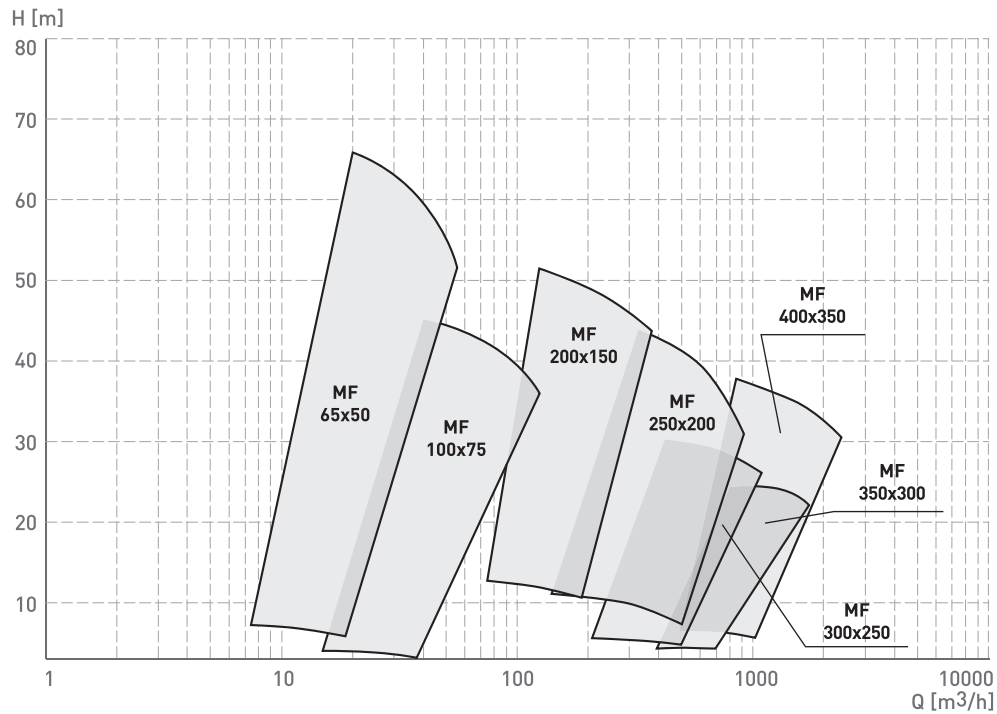

NOMINAL PARAMETERS

Pump type	Capacity Q [m ³ /h]	Head H [m]	Rotation speed n [rpm]	Shaft power P [kW]	Weight m [kg]
MF 65x50	7,5 – 55	5,5 – 65	600 – 1800	30	600
MF 100x75	15 – 125	4 – 44	600 – 2000	30	600
MF 200x150	75 – 375	10,5 – 51	600 – 1200	90	1540
MF 250x200	140 – 920	11 – 44	500 – 1000	160	1660
MF 300x250	210 – 1100	4,5 – 30	300 – 700	200	2415
MF 350x300	450 – 1750	4,5 – 25	300 – 700	250	2890
MF 400x350	490 – 2400	5,5 – 37,5	300 – 700	355	3535

The parameters are specified for clean water of density $\rho = 1000 \text{ kg/m}^3$ and temperature $T = 15^\circ\text{C}$.

Pump type	Maximum size of solids [mm]	Maximum speed of the pump n [rpm]
MF 65x50	2	1800
MF 100x75	3	2000
MF 200x150	5	1200
MF 250x200	7	1000
MF 300x250	9	700
MF 350x300	11	700
MF 400x350	15	700

STATIONARY SLURRY PUMPS

PH

PH are single stage, horizontal heavy-duty slurry pumps for handling mixtures containing high concentration of abrasive solids.

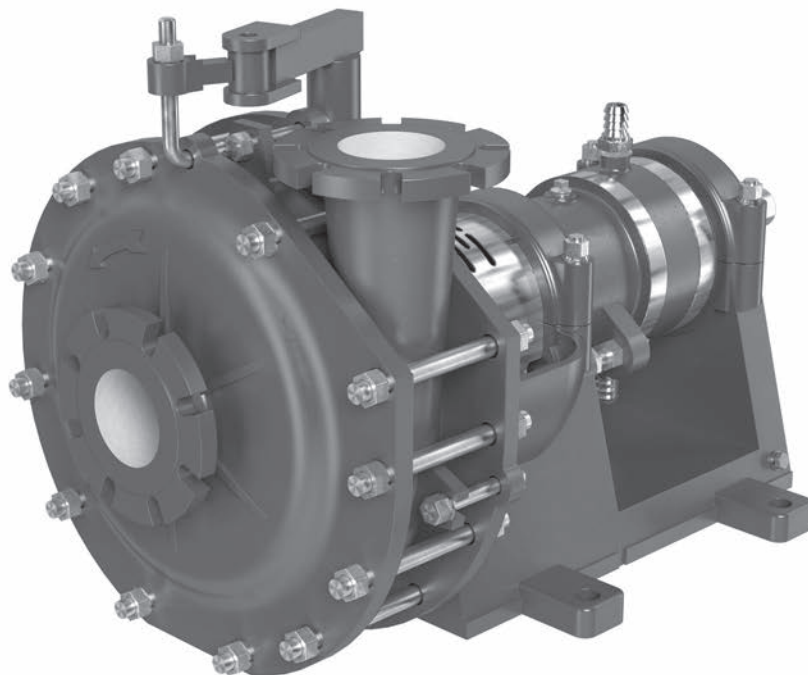

APPLICATION

PH pumps are used for pumping liquids containing significant amounts of solid particles (sludge). Permissible pumpage density is mainly 1700 kg/m^3 , but in individual cases, depending on the type of medium, pumping slurries of higher density is permitted at a limited rotary speed. The maximum allowable size of solid particles (passage) increases with the pump size and can reach 52 mm.

PH pumps are used in the mining industry in processing plants and enrichment of minerals, in hydraulic filling systems, hydraulic waste removal, as well as in other applications where pumping mixtures containing significant amounts of solids is required. PH-Ex pump versions are suitable for use in potentially explosive underground mines, as group I, M2 category installation.

DESIGN

PH pumps are horizontal, single stage, centrifugal pumps, with design adapted for pumping liquid mixtures and solids with abrasive properties. The inlet connection port is at the pump axis and the discharge connection port, in the basic version, is directed vertically upwards, offset laterally in relation to the pump axis.

PH pumps have closed impellers, with a small number of thickened vanes, thus increasing their life and allowing for pumping solid particles of larger size. Impellers are fitted on the front and rear discs with relieving vanes limiting the penetration of solid particles to the area of the shaft seal and the impeller neck sealing gap. This gap forms a frontal slot and its width can be adjusted with wear, without removing the pump, by moving the entire rotating assembly with Bearing housing in relation to the pump stator using special adjustment screws.

PH pumps can be made in a vertical version.

MATERIALS OF CONSTRUCTION

Standard design material version for PH pumps used in manufacturing of the flowing system is hard-wearing alloy steel casting. Cast iron is used for manufacturing bearing elements. Carbon alloy steel casting and copper-cast iron is used in manufacturing of the remaining castings.

PH pumps are also available in the following special versions:

- saline-resistant steel casting version,
- hot water version,
- PH-Ex version designed for areas where explosion hazard is present in underground mines.

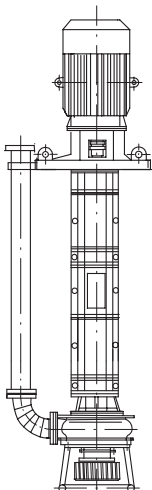

Sample of vertical version.

CROSS-SECTION / LIST OF PUMP PARTS

No.	Part name
1	Suction flange
2	Front liner
3	Impeller
4	Casing
5	Rear liner
6	Stuffing box casing
7	Pedestal
8	Bearing assembly

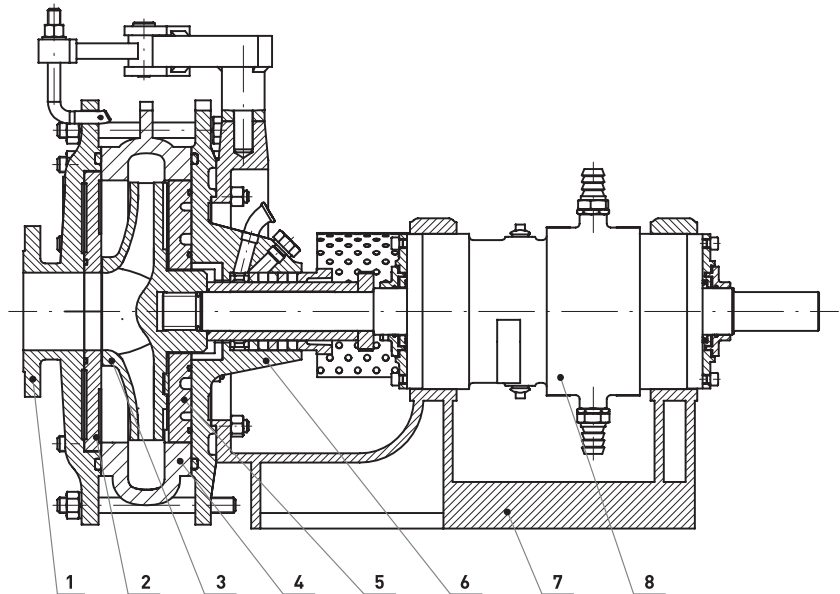

DIMENSIONS

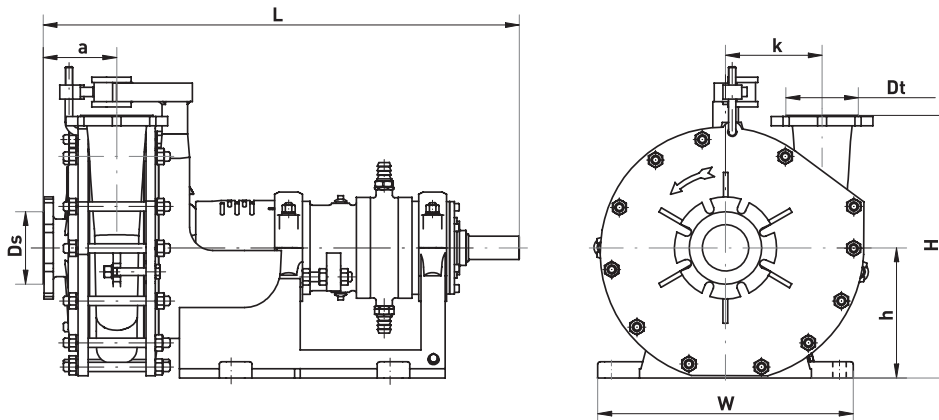

Dimension [mm]	Pump type										
	PH-50 W/ WO/ WG	PH- 65/174	PH- 80/244	PH- 100/332	PH- 100W	PH- 150/440	PH- 200/504	PH- 250/570	PH- 300/725	PH- 100S	PH- 150S
L	826	630	843	1026	1237	1236	1467	1593	1817	1073	1273
a	115	108	127	158	224	202	244	255	286	133	170
W	420	320	420	560	590	590	690	690	910	602	642,5
k	129	112,5	162	208	292	256	347	365	453	212	205
H	445	340	445	565	715	735	975	1080	1200	610	735
h	225	160	225	280	360	335	475	560	630	280	335
Ds	50	70	80	100	150	200	200	250	300	100	150
Dt	50	70	80	100	100	150	200	250	300	100	150

CROSS-SECTION / LIST OF PUMP PARTS PH-S

No.	Part name
1	Bearing assembly
2	Stuffing box casing
3	Wear plate
4	Discharge flange
5	Base
6	Impeller
7	Casing

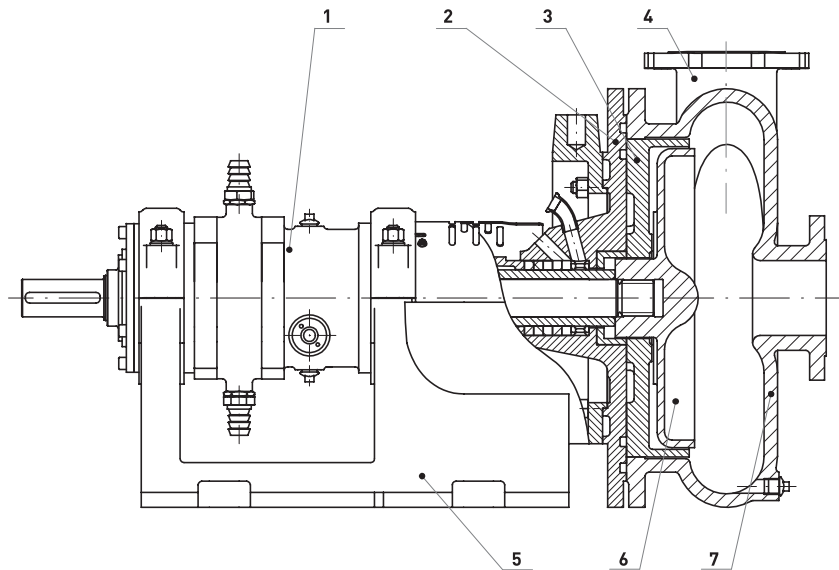

DIMENSIONS

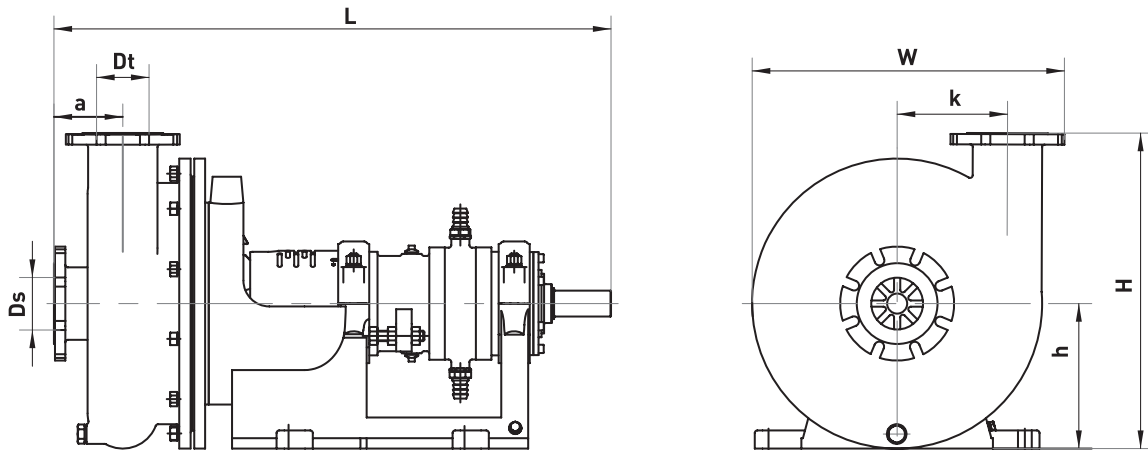

dimensions [mm]	Pump types	
	PH-100S	PH-150S
L	1073	1273
a	133	170
W	602	642,5
k	212	205
H	610	735
h	280	335
Ds	100	150
Dt	100	150

RANGE OF OPERATION

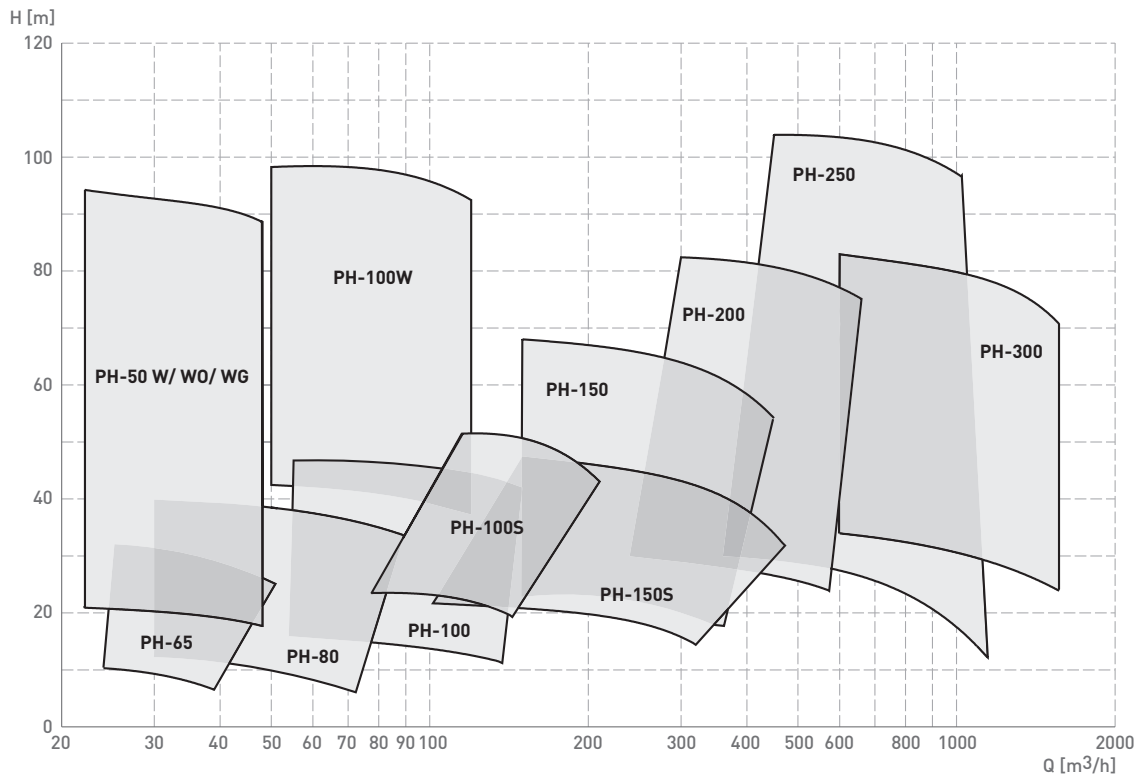

NOMINAL PARAMETERS

Pump type	Capacity Q [m³/h]	Head H [m]	Rotation speed n [rpm]	Shaft power P [kW]	Weight m [kg]
PH-50 W/ WO/ WG	40	74	2945	17	188
PH-65/174	50	25	2650	6,1	94
PH-80/244	80	25	1800	7,8	194
PH-100/332	125	40	1600	21	359
PH-100W	100	95	1470	51	826
PH-150/440	315	63	1450	75	720
PH-200/504	500	80	1450	168	1230
PH-250/570	960	90	1450	308	1522
PH-300/725	1400	73	980	357	2646
PH-100S	185	48	1450	53	330
PH-150S	315	44	1450	80,5	609

The parameters are specified for clean water of density $\rho = 1000 \text{ kg/m}^3$ and temperature $T = 15^\circ\text{C}$.

Pump type	Maximum solid size [mm]	Maximum pressure in the pump [MPa]
PH-50 W/WO/WG	11	1,1
PH-65/174	9	0,64
PH-80/244	11	0,82
PH-100/332	14	0,94
PH-100W	20	1,15
PH-150/440	42	1,42
PH-200/504	50	1,6
PH-250/570	52	1,6
PH-300/725	50	1,6
PH-100S	75	1,0
PH-150S	100	1,05

STATIONARY SLURRY PUMPS

HC

HC pumps are Single stage, horizontal, heavy-duty slurry pumps for handling mixtures containing high concentration of abrasive solids

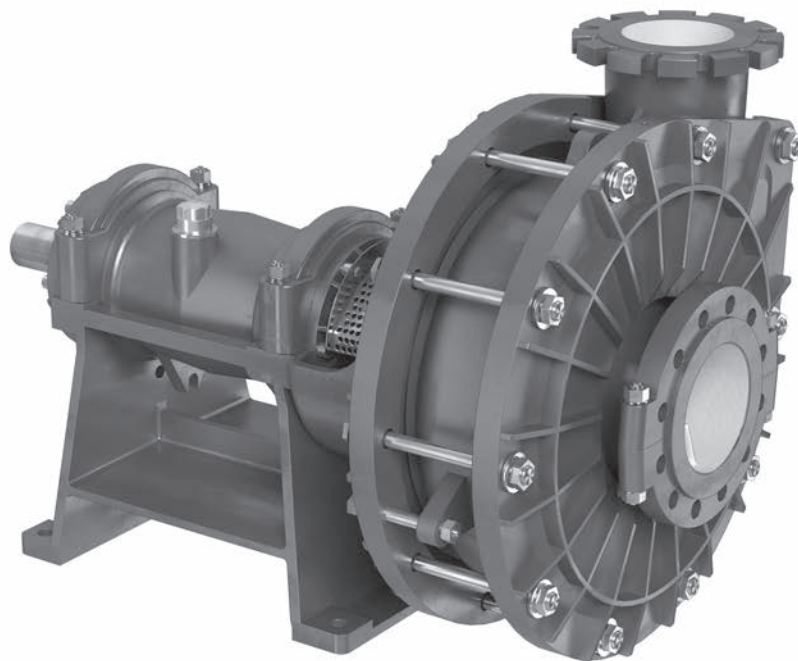

APPLICATION

HC pumps are designed to handle slurries containing high concentration of solids such as sand, gravel, stone, coal, slag, ores, clay, whitewash, tailings etc.

Typical application include:

- Mines – in coal or ore processing plants
- Mineral raw materials mines – for hydraulic transport of sand, gravel and stones
- Power industry – for hydraulic disposal of slag and ash
- Steelworks – for pumping water with scale
- Cement plants – for pumping sand and raw materials
- Sugar factories – for pumping industrial waste

DESIGN

Stationary, single-stage, centrifugal, horizontal slurry pumps with closed impellers. The suction flange is located horizontally at the axis while the delivery flange is located vertically upwards. The pump outer casing is protected from inside by replaceable wear resistant liners. The axial thrust is absorbed by a thrust roller bearing. The bearings are oil lubricated. The shaft is centrifugal consisting of a gland seal fed with grease and of an additional expeller reducing the pressure on the packing. Version with mechanical seal is also available. The whole rotating assembly together with the bearing housing can be shifted along the axial direction without pump disassembly in order to adjust the sealing gap between the impeller and the front liner.

HC pumps can be made in a vertical version.

MATERIALS OF CONSTRUCTION

Wet end components are made of MTL-26 – wear resistant high chromium alloy cast steel

CROSS-SECTION / LIST OF PUMP PARTS

No.	Part name
1	Pedestal
2	Bearing assembly
3	Gland casing
4	Expeller
5	Expeller liner
6	Rear casing
7	Rear liner
8	Casing
9	Impeller
10	Discharge flange
11	Front external casing
12	Suction flange

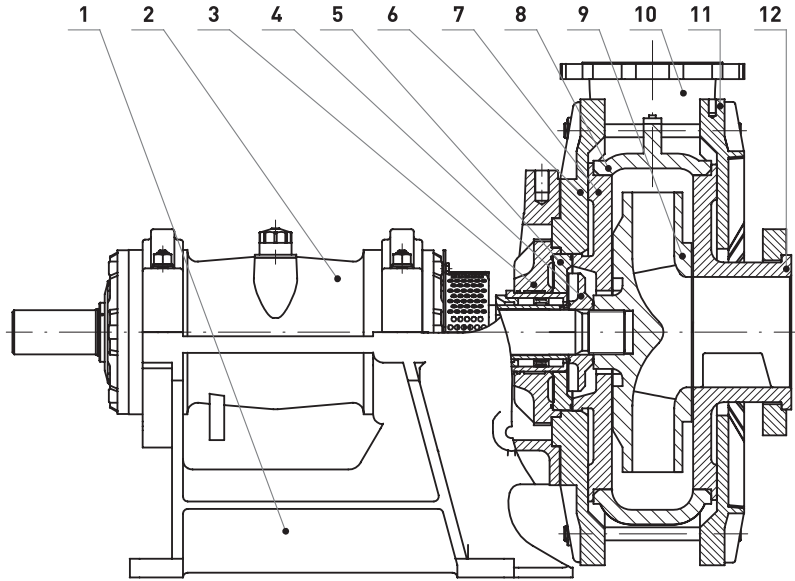

DIMENSIONS

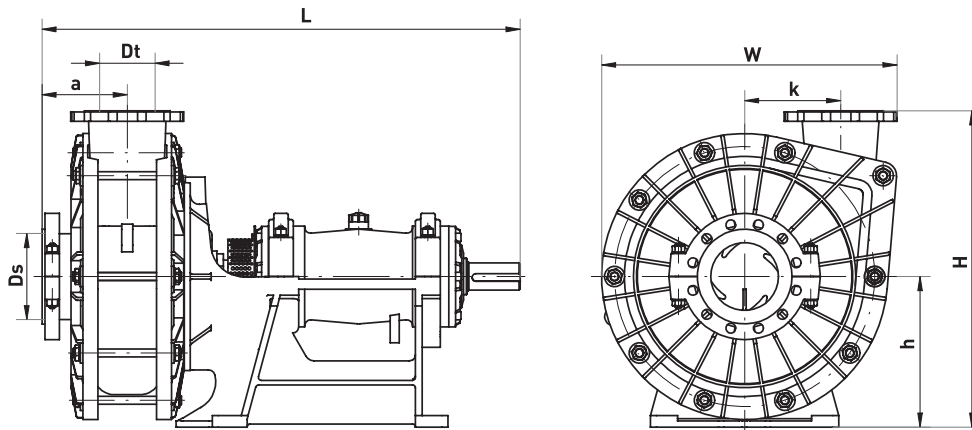

Dimension [mm]	Pump type			
	HC-125	HC-150	HC-150W	HC-200
L	1132	1536	1516	1577
a	220,5	239	229	283
W	~ 786	~ 872	~ 980	~ 980
k	253	280	338	319
H	880	982	1052	1050
h	450	500	500	500
Ds	150	175	175	225
Dt	125	150	150	200



RANGE OF OPERATION

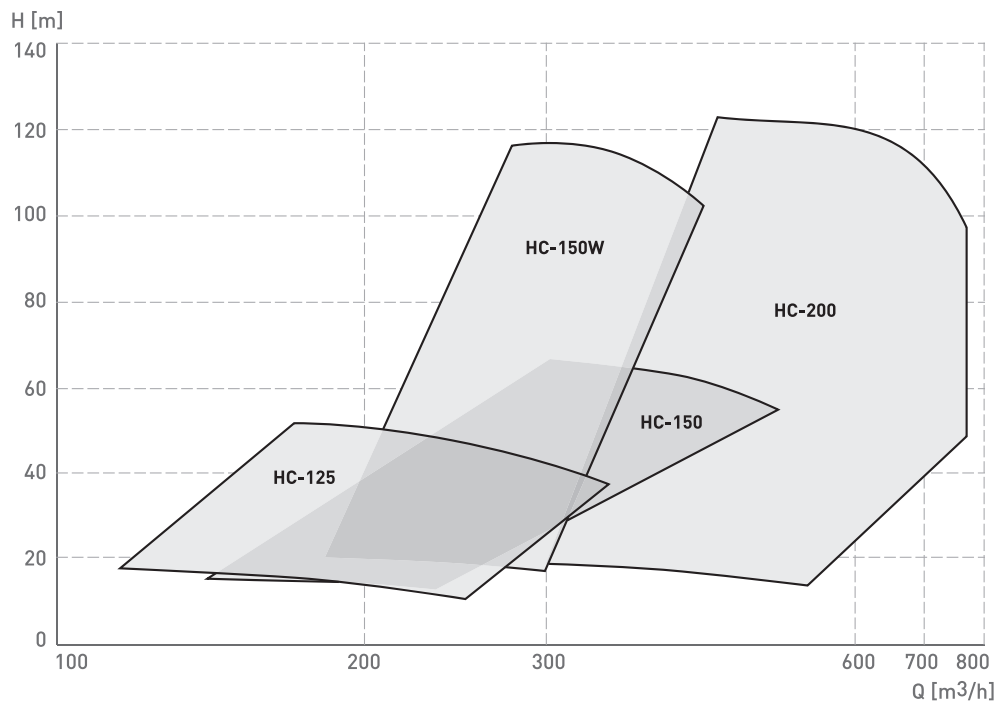

NOMINAL PARAMETERS

Pump type	Capacity Q [m³/h]	Head H [m]	Rotation speed n [rpm]	Shaft power P [kW]	Weight m [kg]
HC - 125/380	250	45	1450	44	ok. 913
HC-150/440	400	63	1470	100	ok. 1447
HC-150/580	400	105	1465	174	ok. 1680
HC-200/570	600	120	1475	300	ok. 1848

The parameters are specified for clean water of density $\rho = 1000 \text{ kg/m}^3$ and temperature $T = 15^\circ\text{C}$.

Pump type	Maximum solid size [mm]	Maximum pressure in the pump [MPa]
HC - 125	25	1,2
HC-150	60	1,6
HC-150W	20	1,6
HC-200	60	1,6

SUBMERSIBLE SLURRY PUMPS

HZ

HZ are submersible heavy-duty slurry pumps for abrasive solids



APPLICATION

HZ pumps are submersible pumps designed to handle water containing significant amounts of solids with dimensions exceeding 100 mm (in version with the free movement impellers) wherein the density of the pumped liquid must not be greater than 1400 kg/m³.

Typical applications:

- For pumping highly contaminated liquids,
- For pumping sludge and similar.

DESIGN

Submersible, vertical single-stage impeller pumps. Free movement or closed impellers are mounted directly on submersible electric motor shaft. Drive motor is located right on the pump part. Hydraulic part located under the engine is separated from the shaft mechanical seal with oil chamber. An inlet to the pump is in axis from the bottom of the pump, and discharge casing is directed to the side perpendicular to the pump axis.

Drive motors have protection against the ingress of external factors IP X8 and are adapted for immersion service up to 6 m. Standard voltage is 400 V, but 500 V version is also available.

HZ pumps are equipped with security systems including motor winding and bearings temperature sensors, presence of moisture sensor in the motor and the presence of water sensor in the oil chamber. The pump has a rack from the bottom, which allow to set pump at the bottom of reservoir.

MATERIALS OF CONSTRUCTION

HZ pumps are made with two different versions of the materials, hard-abrasiveness and salt-resistant.

CROSS-SECTION / LIST OF PUMP PARTS

No.	Part name
1	Power supply cable
2	Handle
3	Motor
4	Pug or oil moisture sensor (optional)
5	Supply pipe
6	Impeller
7	Discharge casing
8	Front liner
9	Base
10	Adjusting screw
11	Adjusting sleeve
12	Mechanical seal
13	Drain plug
14	Oil

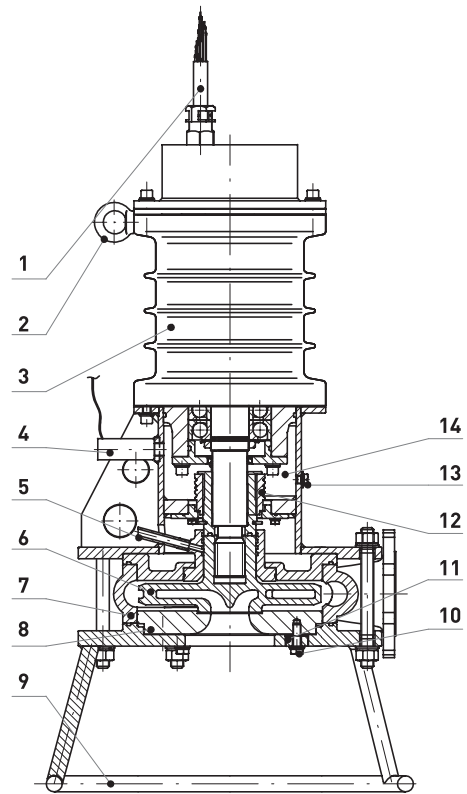

DIMENSIONS

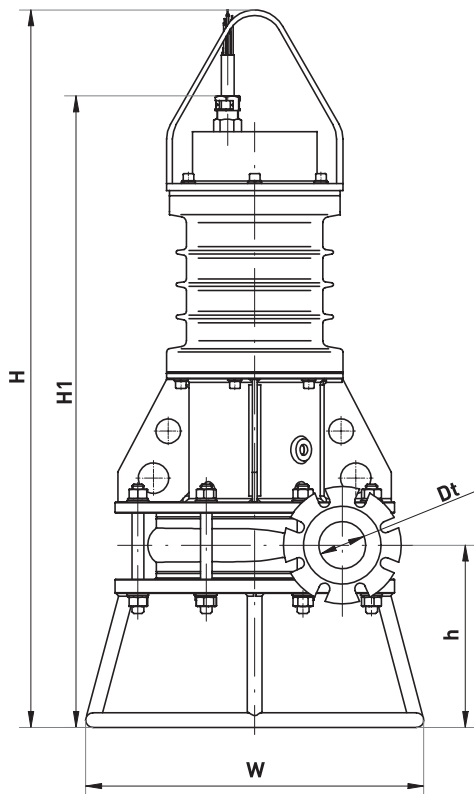

Pump type	Dimension [mm]				
	H	H1	h	W	Dt
HZ-50-7-2	-	1075	310	600	50
HZ-50S-11-1	1201	1131	262	700	50
HZ-50S-18-1	1361	1291	262	700	50
HZ-50-22-1	1292	1222	268	700	50
HZ-50S-30-1	1408	1338	252	700	50
HZ-80-7-3	-	1150	316	595	80
HZ-80-22-2	1445	1270	320	575	80
HZ-80-37-2	1100	-	320	575	80
HZ-175-37-3	1709	-	590	1000	175



RANGE OF OPERATION

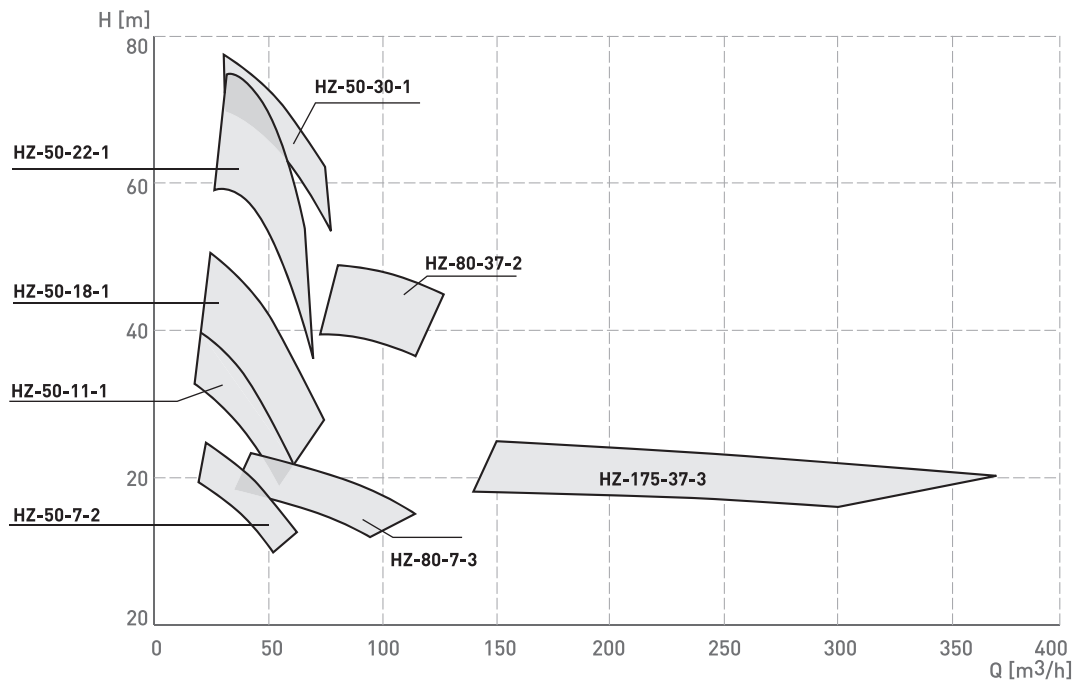

NOMINAL PARAMETERS

Pump type	Capacity Q [m³/h]	Head H [m]	Rotation speed n [rpm]	Motor rated power P _s [kW]	Weight m [kg]
HZ-50-7-2	40	20	1465	7,5	274
HZ-50S-11-1	25	34	2930	11	278
HZ-50S-18-1	50	42	2930	18,5	325
HZ-50-22-1	45	61	2920	22	412
HZ-50S-30-1	60	69	2940	30	370
HZ-80-7-3	40	19	960	7,5	398
HZ-80-22-2	90	40	1465	22	477
HZ-80-37-2	125	44	1475	37	661
HZ-175-37-3	250	21	980	37	1245

The parameters are specified for clean water of density $\rho = 1000 \text{ kg/m}^3$ and temperature $T = 15^\circ\text{C}$.

SUBMERSIBLE PUMPS

OSZ

OSZ pumps are vertical, multistage submersible pumps for mechanically and chemically contaminated fluids



APPLICATION

OSZ pumps are typically applied for open cast mine and deep mine dewatering. They are also applicable in any other case when submersible pumps of medium capacity and head are required to pump contaminated water.

DESIGN

Multi-stage, vertical, submersible centrifugal pumps with closed impellers and vane diffusers. Water inlet is located around the perimeter between the pump and the motor while the delivery flange is directed horizontally at the upper part of the pump.

The roller bearings are installed in oil chambers sealed by mechanical seals. Thus the presence of abrasive solids in the pumped fluid does not affect the bearing operation. The upper bearing absorbs the axial thrust.

The pump is driven by dry type submersible motor located under the pump. The power from electric motor is transmitted via a flexible coupling. The motor has own roller bearings. The pump set is equipped with the monitoring system including bearings and motor windings temperature sensors as well as water presence sensors in the oil chambers and in the motor.

MATERIALS OF CONSTRUCTION

Impellers, diffusers, casings are made of cast iron or stainless cast steel

CROSS-SECTION / LIST OF PUMP PARTS

No.	Part name
1	Discharge flange
2	Stage casing
3	Tie bolt
4	Guide vane
5	Vane diffuser
6	Impeller
7	Bearings
8	Suction strainer
9	Hanger
10	Hanging bracket
11	Mechanical seal
12	Level sensor
13	Shaft
14	Mechanical seal
15	Suction casing
16	Motor

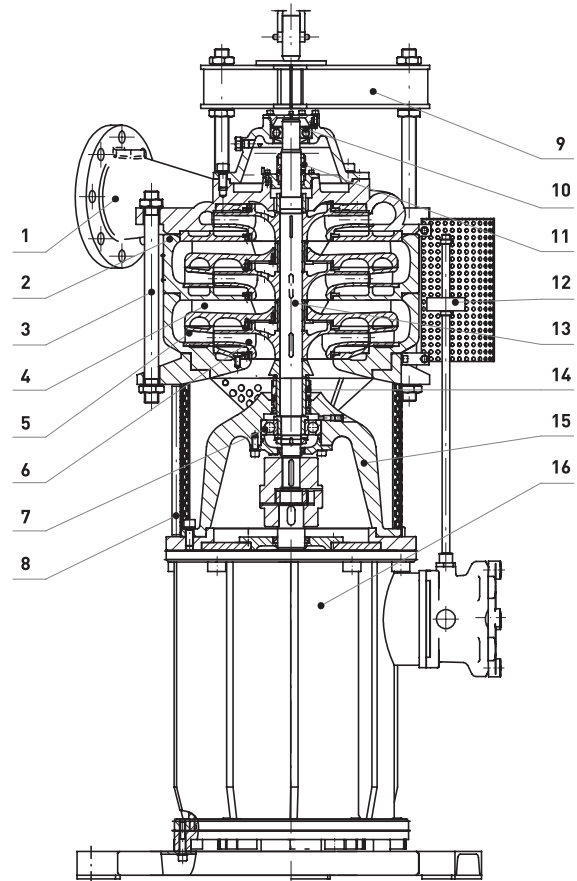

DIMENSIONS

Dimension [mm]	Pump type			
	OSZ-100		OSZ-150	
Number of stages	3	2	3	2
H	1600	1500	1700	1574
h	1360	1260	1443	1317
W	860		880	
Dt	100		150	

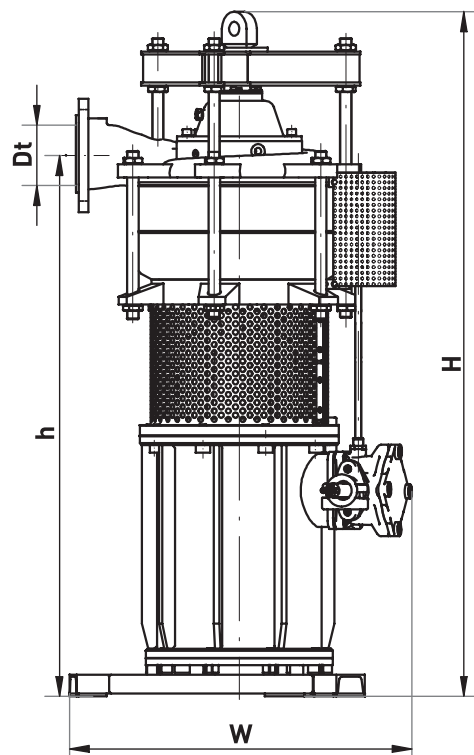

RANGE OF OPERATION

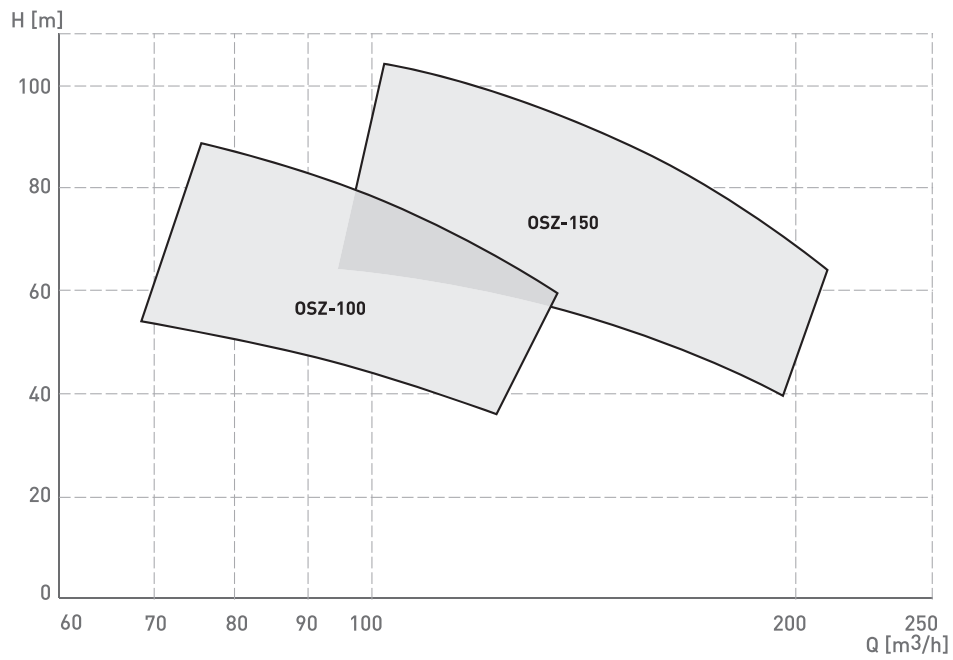

NOMINAL PARAMETERS

Pump type	Number of stages	Capacity Q [m³/h]	Head H [m]	Rotation speed n [rpm]	Motor rated power P _s [kW]	Weight m [kg]
OSZ-100	2	90	56	1475	37	827
	3		84			892
OSZ-150	2	155	58	1475	75	1044
	3		87			1150

The parameters are specified for clean water of density $\rho = 1000 \text{ kg/m}^3$ and temperature $T = 15^\circ\text{C}$.

SUBMERSIBLE PUMPS

SP

SP pumps are designed to handle mine and industrial water containing solids



APPLICATION

SP pumps are designed to handle mine and industrial water containing solids.

Typical applications include:

- underground mines – for mine face dewatering, including cases where methane hazard or coal dust explosion hazard are present,
- construction site dewatering.

DESIGN

Submersible, single stage impeller pumps with closed impellers mounted directly on electric motor shaft under the motor. The motor is cooled by the fluid pumped through a cooling jacket. The delivery flange is located at the upper part of the pump. Pump shaft is sealed by double mechanical seal in the oil chamber between the impeller and the motor.

The pump set is equipped with monitoring system consisting of motor bearings and windings temperature sensors, moisture sensors and electric protections against overload or dry run of the pump.

The pumps are compliant with Atex directive and are certified for operation at sites exposed to explosion hazard – I M2c, EEx dl.

Non Atex version of smaller mass is also available.

MATERIALS OF CONSTRUCTION

Standard version: impeller – wear-resistant cast steel, pump casing– aluminum alloy, shaft, bolts, nuts – stainless steel.

In salt-resistant version all elements are made of stainless cast steel.

SECTIONAL VIEW / LIST OF PUMP PARTS

No.	Part name
1	Discharge flange
2	Handle
3	Mechanical seal
4	Discharge casing
5	Key
6	Washer
7	Impeller nut
8	Motor
9	Mechanical seal
10	Impeller
11	Suction cover
12	Suction rose

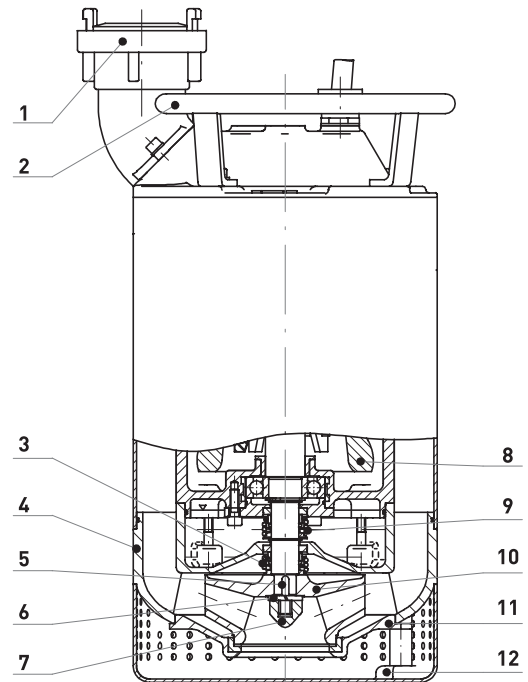

DIMENSIONS

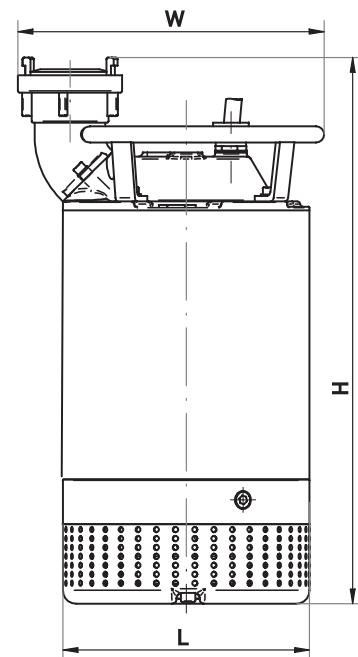

Dimensions [mm]	Pump type		
	6SP13	6SP14-Ex	6SP16
L	222	276	303
W	308	343	314
H	620	611	865

RANGE OF OPERATION

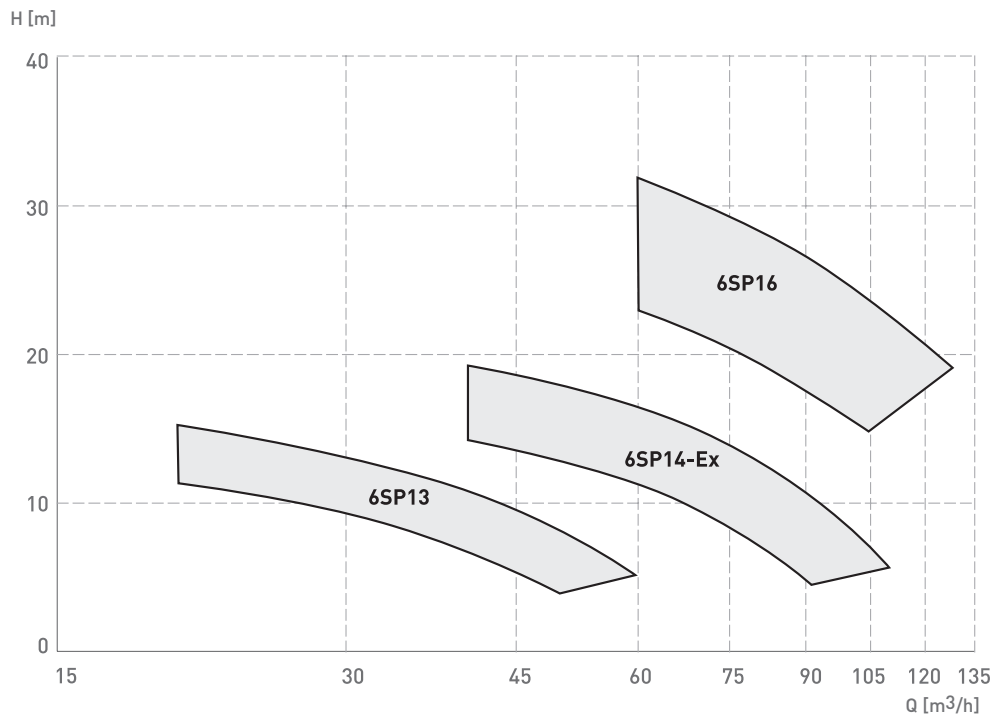

NOMINAL PARAMETERS

Pump type	Capacity Q [m ³ /h]	Head H [m]	Rotation speed n [rpm]	Motor rate power P _s [kW]	Weight m [kg]
6SP13	32	12,5	3000	3	30
6SP14-Ex	63	16	3000	5,5	65
6SP16	95	25	3000	11	70

The parameters are specified for clean water of density $\rho = 1000 \text{ kg/m}^3$ and temperature $T = 15^\circ\text{C}$.

SUBMERSIBLE PUMPS

NZ

Submersible pumps NZ are designed
to deal with water
containing solids and salt

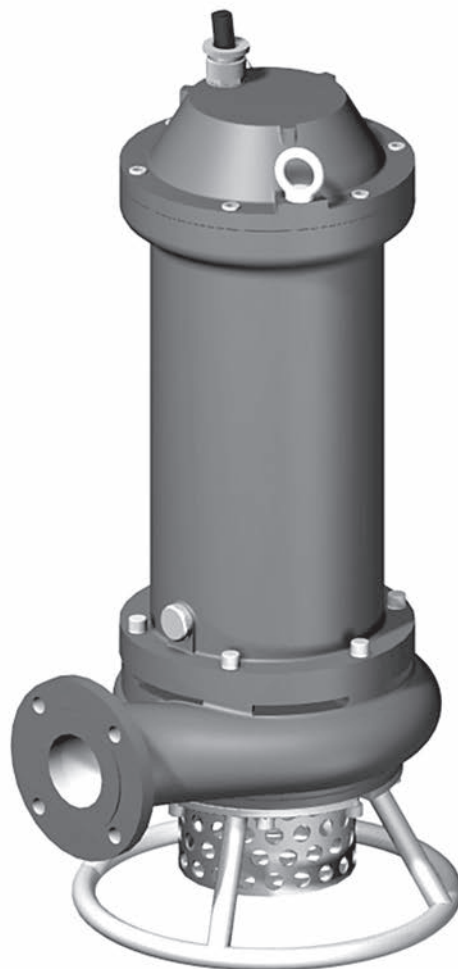

APPLICATION

Submersible pumps NZ type are designated to handle mixtures of water with solids of dimensions up to 15 mm for 6NZ15 pump, 10 mm for 6NZ18 pump and 32 mm for 10NZ22 pump. The density of pumped mixture must not exceed 1200 kg/m³.

Typical applications:

- for local dewatering in coal, ore and minerals mines as well as in power industry.

DESIGN

Submersible, vertical single-stage centrifugal pumps. The impeller is installed directly on the shaft end of a submersible electric motor. Motor is assembled over the pump. The hydraulic assembly is located under the motor and is separated from it by a mechanical seal in an oil chamber. The pump inlet is located at the axis under the pump and the delivery flange is directed horizontally, perpendicularly to the axis.

The motors are of IP 68 protection class and are designed to operate in submergence up to 20 m. A support is provided in lower part the pump in order to place the pump on the sump bottom.

The pump sets are equipped with electric protection systems against overload and dry-run. Bearing temperature sensors are provided.

Pumps can be equipped with motors for various supply voltages 400V, 500V, 660V, 1140V and switchable 500V/1000V. The pumps are compliant with ATEX directive and are certified for operation in explosion hazardous areas – I M2c Ex dl. Mb.

MATERIALS OF CONSTRUCTION

Pump impellers are made of wear resistant alloy cast steel. The casings are made of cast iron. Nuts, bolts and pump supports are made of stainless steel.

SECTIONAL VIEW / LIST OF PUMP PARTS

No.	Part name
1	Power supply cable
2	Handle
3	Motor
4	Shaft
5	Mechanical seal
6	Seal chamber
7	Impeller
8	Impeller nut
9	Delivery casing
10	Suction cover
11	Support

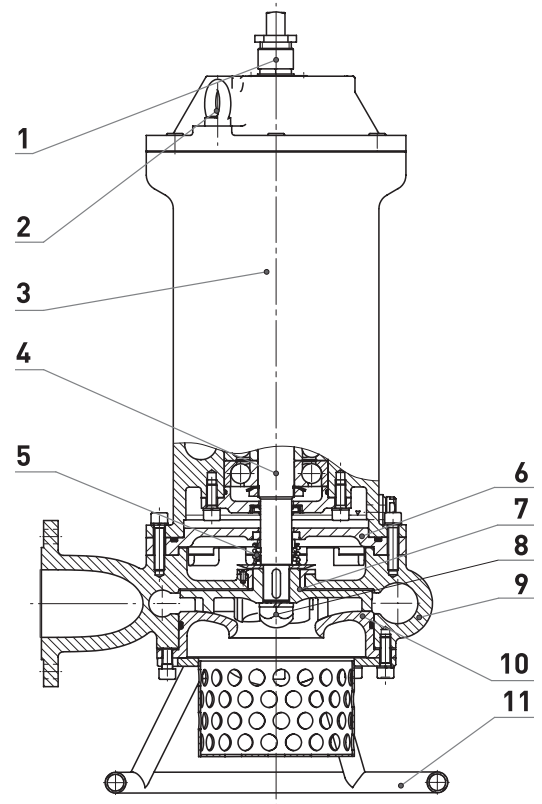

DIMENSIONS

Dimensions [mm]	Pump type		
	6NZ15	6NZ18	10NZ22
A	720	760	1100
B	330	330	520
C	390	390	564
D	225	226	304

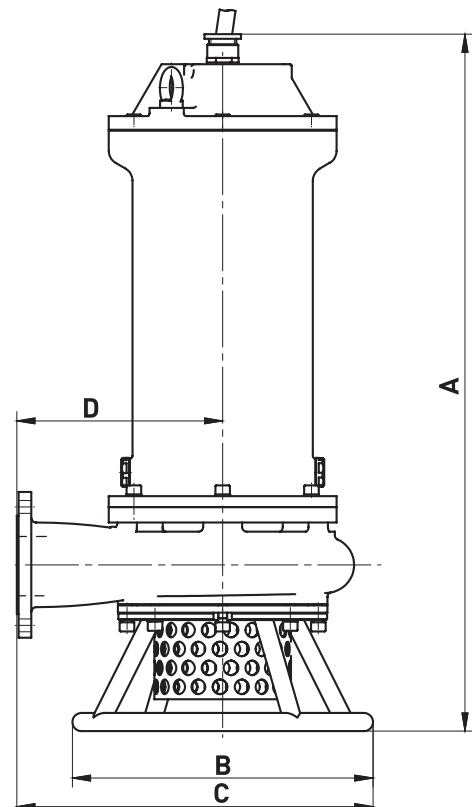

RANGE OF OPERATION

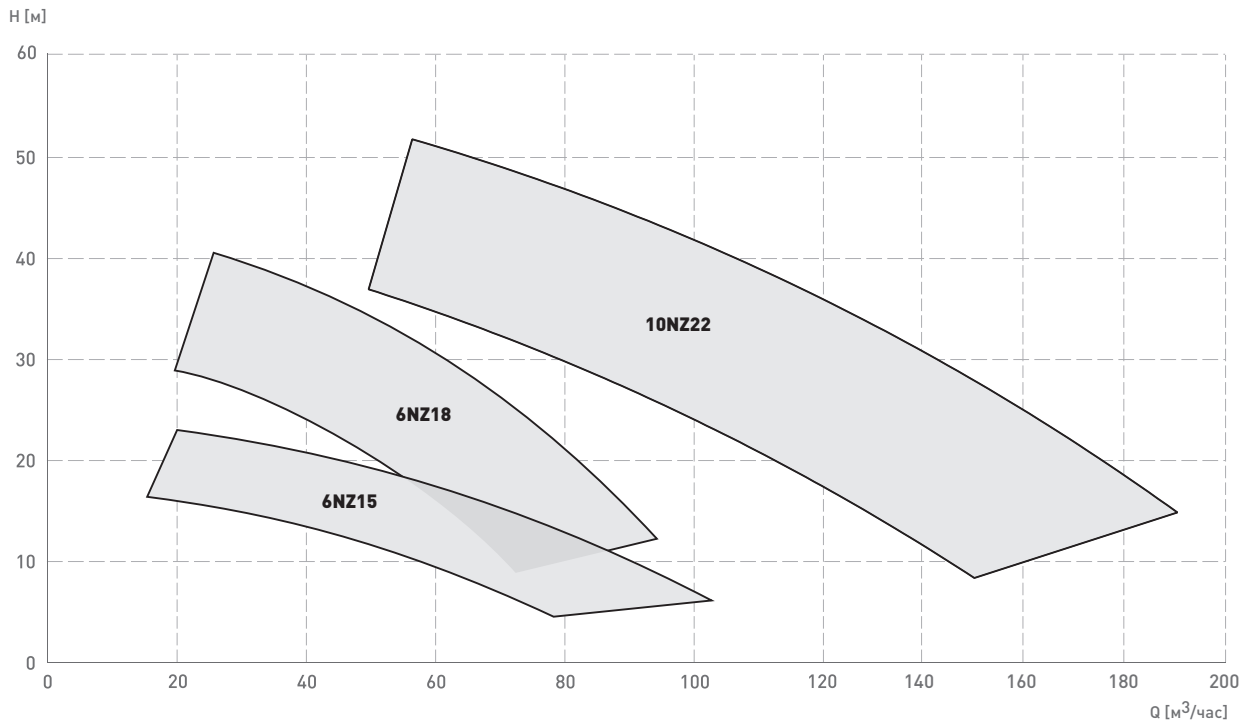

NOMINAL PARAMETERS

Pump type	Capacity Q [m³/h]	Head H [m]	Rotation speed n [rpm]	Motor rated power P _s [kW]	Weight m [kg]
6NZ15-Ex	60	15	3000	5,5	87
6NZ18-Ex	45	27	3000	7,5	98
10NZ22-EX	125	37	3000	22	275
6NZ15	60	15	3000	5,5	87
6NZ18	45	27	3000	7,5	98
10NZ22	125	37	3000	22	275

The parameters are specified for clean water of density $\rho = 1000 \text{ kg/m}^3$ and temperature $T = 15^\circ\text{C}$.

SUBMERSIBLE PUMPS

P-BA

P-BA pumps are single stage submersible pumps for handling mechanically and chemically contaminated fluids



APPLICATION

P-BA pumps are designed to handle mine and industrial water containing solids.

Typical applications include:

- Underground mines – for mine face dewatering, including cases where methane hazard or coal dust explosion hazard are present,
- construction site dewatering

DESIGN

Submersible, single stage impeller pumps with closed impellers mounted directly on electric motor shaft under the motor. The motor is cooled by the fluid pumped through a cooling jacket. The delivery flange is located at the upper part of the pump. Pump shaft is sealed by double mechanical seal in the oil chamber between the impeller and the motor.

The pump set is equipped with monitoring system consisting of motor bearings and windings temperature sensors, moisture sensors and electric protections against overload or dry run of the pump.

The pumps are compliant with Atex directive and are certified for operation at sites exposed to explosion hazard – I M2c, EEx dI. Non Atex version of smaller mass is also available.

MATERIALS OF CONSTRUCTION

Standard version: impeller – wear-resistant cast steel, pump casing– aluminum alloy, shaft, bolts, nuts – stainless steel. In salt-resistant version all elements are made of stainless cast steel.

SECTIONAL VIEW / LIST OF PUMP PARTS

No.	Part name
1	Discharge pipe quick release joint
2	Motor
3	Shaft
4	Draining plug
5	Discharge casing
6	Connecting bolt
7	Suction strainer
8	Handle
9	Mechanical seal
10	Spring washer
11	Impeller nut
12	Impeller
13	Suction cover

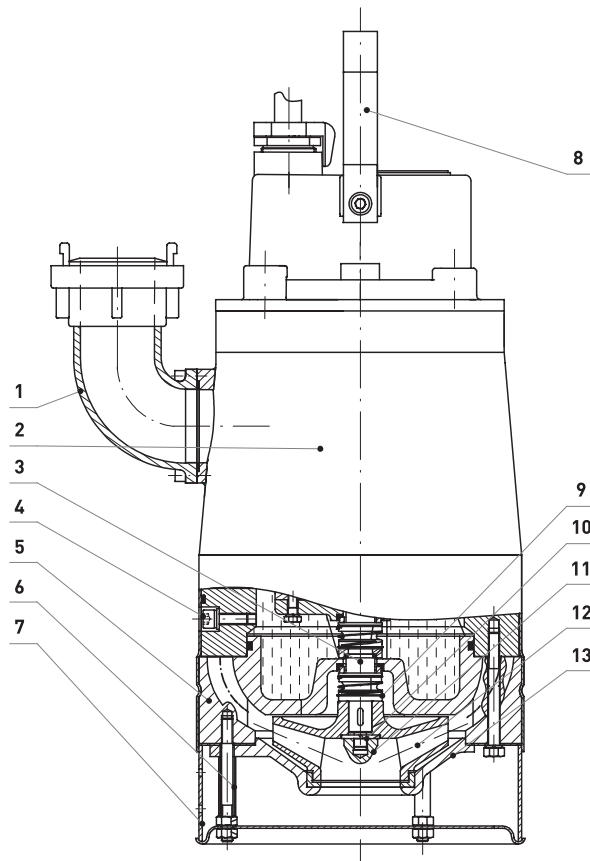

DIMENSIONS

Dimensions [mm]	Pump type	
	P-1BA-Ex	P-2BA-Ex
W	375	411
D	258	290
H	590	676
h	490	515
Dt	65	65

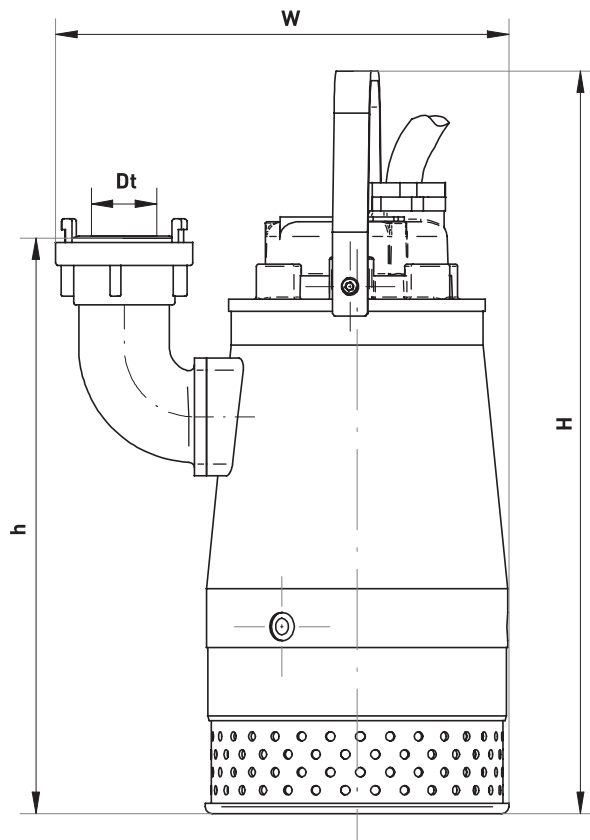

RANGE OF OPERATION

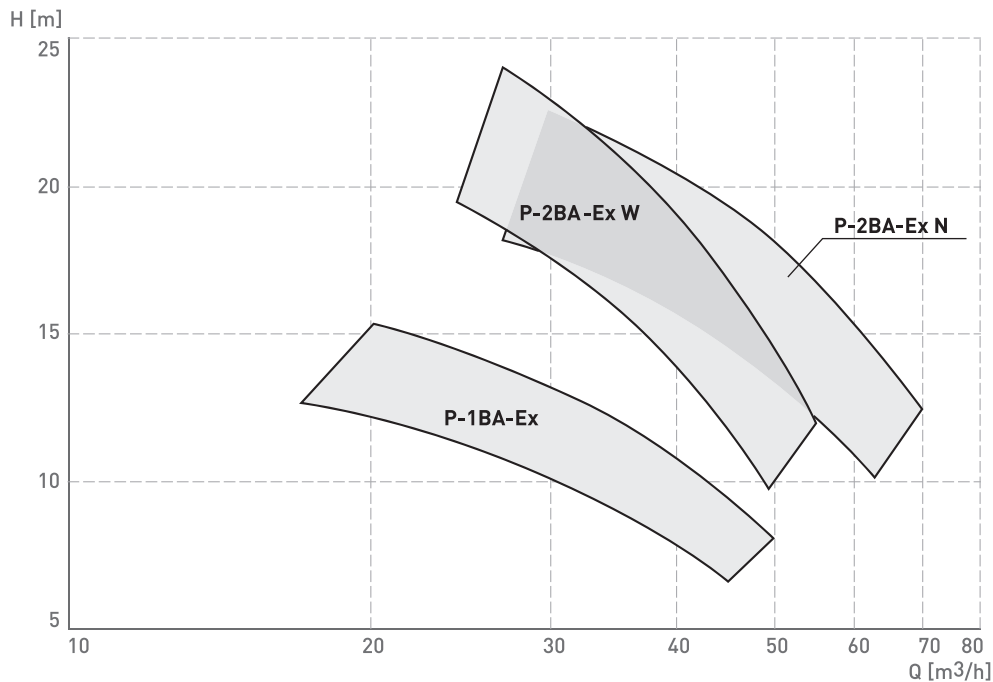

NOMINAL PARAMETERS

Pump type	Capacity Q [m³/h]	Head H [m]	Rotation speed n [rpm]	Motor rated power P _s [kW]	Weight m [kg]
P-1BA/I-Ex	32	12,5	2840	2,2	62
P-1BA-Ex	32	12,5	2840	2,2	62
P-1BA/D-Ex	32	12,5	2840	2,2	62
P-1BA/E-Ex	32	12,5	2840	2,2	62
P-1BA/EC-Ex	32	12,5	2840	2,2	62
P-1BA/A	32	12,5	2840	2,2	62
P-2BA-Ex wyk N/wykW	36/42	21/18	2865	4	83
P-2BA/D-Ex wyk N/wykW	36/42	21/18	2865	4	83
P-2BA/E-Ex wyk N/wykW	36/42	21/18	2865	4	83
P-2BA/EC-Ex wyk N/wykW	36/42	21/18	2865	4	83
P-2BA/A wyk N/wykW	36/42	21/18	2865	4	83

The parameters are specified for clean water of density $\rho = 1000 \text{ kg/m}^3$ and temperature $T = 15^\circ\text{C}$.

www.powen.eu



INNOVATIVE ECONOMY
NATIONAL COHESION STRATEGY



Grupa Powen-Wafapomp SA

EUROPEAN UNION
EUROPEAN REGIONAL
DEVELOPMENT FUND

